

# METHOW RIVER FOGHORN REACH RESTORATION PROJECT PHASE 1

## FINAL DESIGN DRAWINGS



**PREPARED FOR:**  
 YAKAMA NATION FISHERIES  
 ATTN: JARRED JOHNSON  
 (509) 881-1462  
 EMAIL: JOHJ@YAKAMAFISH-NSN.GOV

**PREPARED BY:**  
 RIO APPLIED SCIENCE & ENGINEERING, LLC  
 ATTN: JOE YOUNG, PE  
 3380 W. AMERICANA TERRACE, SUITE 390  
 BOISE, ID 83705  
 (208) 484-4700  
 EMAIL: JOE@RIOASE.COM

**PROJECT GOALS:**

- IMPROVE POOL QUANTITY/QUALITY AND COVER FOR ADULT HOLDING AND SUMMER/WINTER REARING FOR SPRING AND SUMMER CHINOOK SALMON, BULL TROUT, COHO SALMON, STEELHEAD, AND LAMPREY.
- IMPROVE OR MAINTAIN ATTRACTIVE FLOW TO THE METHOW PUD HATCHERY VOLITIONAL CHANNEL.
- IMPROVE WIDTH TO DEPTH RATIO AT CONFLUENCE OF VOLITIONAL CHANNEL AND METHOW RIVER TO IMPROVE PASSAGE FOR RETURNING ADULT SALMON (NEAR BASEFLOW CONDITIONS).
- MINIMIZE RISK TO PUBLIC SAFETY IN THE MAINSTEM METHOW RIVER.
- AVOID INCREASE IN FLOOD HEIGHT AND EROSION FORCE (SHEAR STRESS) THAT MAY ADVERSELY AFFECT PRIVATE PROPERTY AND INFRASTRUCTURE.

**PROJECT OBJECTIVES:**

- INSTALL ENGINEERED LARGE WOOD HABITAT STRUCTURES WITH EXCAVATED POOLS IN LOCATIONS WHERE HYDRAULICS WILL MAINTAIN PERSISTENT HABITAT.
- IMPROVE PASSAGE INTO HATCHERY CHANNEL OUTLET AT THE CONFLUENCE WITH THE METHOW RIVER.

SHEET INDEX		
SHEET COUNT	SHEET TITLE	SHEET NUMBER
GENERALS		
1	COVER	G1
2	GENERAL NOTES 1	G2
3	HIP CONSERVATION MEASURES 1	G3
4	HIP CONSERVATION MEASURES 2	G4
5	HIP CONSERVATION MEASURES 3	G5
6	CONSTRUCTION QUANTITIES	G6
EXISTING CONDITIONS		
7	OVERVIEW	C1
PROPOSED CONDITIONS		
8	ACCESS AND STAGING	C2
9	CONSTRUCTION SEQUENCING	C3
10	OVERVIEW AND KEY MAP	C4
11	NORTH WORK AREA	C5
12	SOUTH WORK AREA	C6
DETAILS		
13	HS-1 - THREE LOG STRUCTURE	D1
14	HS-2 - LOW PROFILE BANK JAM	D2
15	HS-3 - LARGE BANK JAM	D3
16	HS-4 - SINGLE LOG	D4
17	ROUGHENED EDGE	D5
18	CONSTRUCTED RIFFLE	D6
19	ACCESS & ISOLATION DETAILS	D7

METHOW RIVER FOGHORN REACH  
 RESTORATION PROJECT PHASE 1

FINAL DESIGN DRAWINGS

FOR: YAKAMA NATION FISHERIES  
 METHOW RIVER - FOGHORN REACH  
 OKANOGAN COUNTY, WASHINGTON

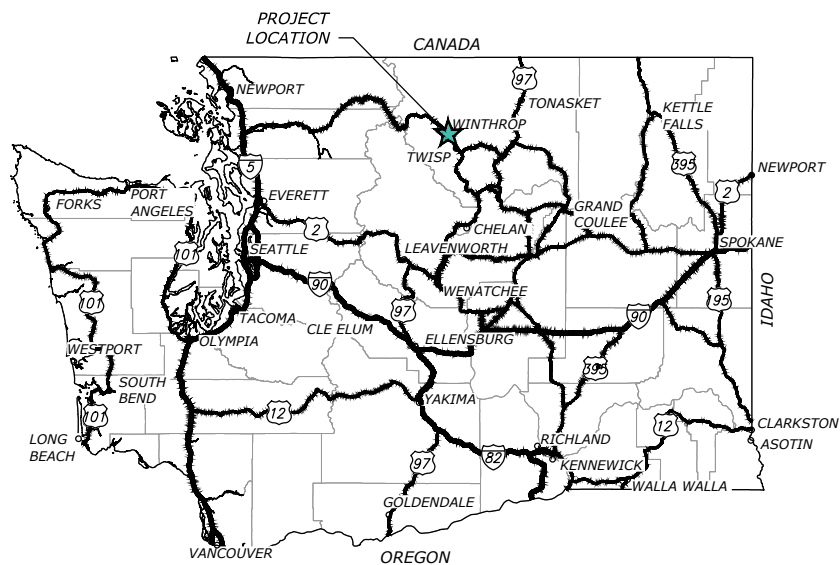

LOCATION MAP  
 NOT TO SCALE



VICINITY MAP  
 NOT TO SCALE



PROJECT MAP  
 NOT TO SCALE



DATE: APRIL 3, 2026  
 DESIGNED: TDS, SJB  
 APPROVED: JCY

DRAWING NAME  
 GENERALS

COVER

DRAWING NO.  
 G1  
 SHEET 1 OF 19

FILE: R:\PROJECTS\METHOW\_RIVER\_FOGHORN\_REACH\_RESTORATION\HUC1510030\METHOW\_RIVER\_FOGHORN\_REACH\_RESTORATION\_GENERALS.DWG SAVED BY: TIM SICKLES PLOT DATE: 4/2/2026 12:35 PM

**GENERAL NOTES AND REQUIREMENTS**

**GENERAL**

1. PROJECT COORDINATE SYSTEM (HORIZONTAL DATUM) IS NAD83 WASHINGTON STATE PLANE, NORTH ZONE, US FOOT. THE VERTICAL DATUM IS NAVD88.
2. THE WASHINGTON STATE DEPARTMENT OF TRANSPORTATION STANDARD SPECIFICATIONS FOR ROADS, BRIDGES, AND MUNICIPAL CONSTRUCTION (WSDOT STANDARD SPECIFICATIONS, 2018 EDITION) SHALL APPLY UNLESS OTHERWISE NOTED IN THE DRAWINGS OR PROJECT SPECIAL PROVISIONS (SPECIFICATIONS).
3. TOPOGRAPHIC MAPPING WITHIN THE PROJECT AREA IS BASED ON 2022 GREEN TOPOBATHYMETRIC LIDAR DATA COLLECTED BY NV5. ALL DIMENSIONS ON THE DRAWINGS ARE IN UNITS OF FEET AND DECIMALS, UNLESS OTHERWISE SPECIFIED.

**DESCRIPTION OF WORK**

1. THIS PROJECT WILL IMPROVE BANK, CHANNEL, RIPARIAN, AND AQUATIC HABITAT CONDITIONS TO ADDRESS LIMITING FACTORS ASSOCIATED WITH ESA LISTED CHINOOK SALMON AND STEELHEAD WITHIN THE METHOW RIVER. IT WILL INCREASE IN-STREAM HYDRAULIC DIVERSITY, STREAM COVER, AND MICROHABITATS ALONG CHANNEL MARGINS, INCREASE FREQUENCY, DURATION, AND AREA OF FLOODPLAIN INUNDATION, AND IMPROVE RIPARIAN COMMUNITIES.
2. THE WORK WILL INCLUDE THE FOLLOWING ACTIVITIES AS SHOWN ON THE DRAWINGS: INSTALLATION AND REMOVAL OF TEMPORARY CONSTRUCTION ACCESS ROUTES AND COFFERDAMS, DEWATERING, EARTHWORK WITHIN THE EXISTING CHANNEL AND FLOODPLAIN (EXCAVATION OF PILOT CHANNELS), INSTALLATION OF MULTIPLE WOOD HABITAT STRUCTURES TO ENHANCE AQUATIC HABITAT, AND REVEGETATION OF ALL DISTURBED AREAS (PLANTING AND/OR SEEDING). ALL WORK SHALL BE COMPLETED IN ACCORDANCE WITH THE CONTRACT DOCUMENTS, DRAWINGS, AND SPECIFICATIONS.

**PROJECT ROLES**

1. THE ABOVE WORK IS TO BE PERFORMED FOR YAKAMA NATION FISHERIES, HEREAFTER REFERRED TO AS THE "SPONSOR". ONLY THE SPONSOR MAY APPROVE CHANGES TO THE CONTRACT AMOUNT AND THE CONTRACT REQUIREMENTS. THE SPONSOR WILL APPOINT A PROJECT STAFF MEMBER, HEREAFTER REFERRED TO AS "CONTRACTING OFFICER", WHO WILL ADMINISTER THE CONSTRUCTION CONTRACT AND PAYMENTS, BE THE PRIMARY POINT OF CONTACT WITH THE CONTRACTOR, ENGINEER, AND REGULATORY AGENCIES, DISTRIBUTE INFORMATION, REVIEW AND COORDINATE DESIGN CHANGES, SUBMITTALS, AND REQUESTS FOR INFORMATION (RFI'S), PERFORM FIELD OVERSIGHT AND INSPECTIONS, AND COORDINATE PRE-FINAL AND FINAL INSPECTIONS AND DEVELOP ASSOCIATED PUNCH LIST ITEMS. THE CONTRACTING OFFICER WILL ALSO COORDINATE ALL FISH SALVAGE ACTIVITIES (TO BE COMPLETED BY PROJECT PARTNERS) AND WILL BE RESPONSIBLE FOR COORDINATION WITH PROPERTY OWNERS.
2. RIO ASE, HEREAFTER REFERRED TO AS THE "ENGINEER," IS THE SPONSOR'S REPRESENTATIVE WHO HAS DESIGNED THE PROJECT. THE ENGINEER PROVIDES CLARIFICATION TO THE CONTRACTOR AND/OR CONTRACTING OFFICER REGARDING THE INTENT OF THE DRAWINGS AND SPECIFICATIONS AND WHETHER ALL THE PROPOSED OR COMPLETED WORK IS IN COMPLIANCE WITH THE DRAWINGS AND SPECIFICATIONS. THE ENGINEER WILL ALSO REVIEW ANY PROPOSED DESIGN CHANGES, SUBMITTALS, AND RFI'S, AND HELP TO PREPARE PRE-FINAL AND FINAL PUNCH LIST ITEMS.
3. THE OWNERS OF THE PROPERTY WHERE CONSTRUCTION WILL OCCUR ARE DOUGLAS COUNTY PUD, METHOW CONSERVANCY, JULIE MUYLLAERT, JESSICA KLEIN, AND, HEREIN REFERRED TO AS THE "PROPERTY OWNERS."
4. CONSTRUCTION OBSERVATION MAY BE PROVIDED BY THE SPONSOR AND THE ENGINEER. CONSTRUCTION OBSERVERS WILL NOT DIRECT THE CONTRACTOR IN ANY WAY BUT WILL ADVISE THE CONTRACTING OFFICER REGARDING THE TECHNICAL REQUIREMENTS OF THE DRAWINGS AND SPECIFICATIONS, AND WHETHER THE ONGOING WORK IS IN COMPLIANCE OR IF THERE ARE DISCREPANCIES. THE CONSTRUCTION OBSERVERS ARE NOT RESPONSIBLE FOR THE CONSTRUCTION MEANS, METHODS, TECHNIQUES, PROCEDURES AND/OR SAFETY OF THE CONTRACTOR.
5. CONTRACTOR SHALL COORDINATE ALL WORK AND ACCESS TO THE SITE WITH THE CONTRACTING OFFICER.







**WORK SCHEDULE**

1. THE CONTRACTOR SHALL COMPLETE ALL CONSTRUCTION INCLUDING CORRECTION AND ACCEPTANCE OF DEFECTIVE WORK AND DEMOBILIZATION PRIOR TO \_\_\_\_\_.
2. THE APPROVED IN-WATER WORK WINDOW FOR THIS PROJECT IS JULY 1 TO JULY 31. ALL WORK REQUIRING EQUIPMENT TO OPERATE PARTLY, OR WHOLLY, BELOW THE ORDINARY HIGH WATER LINE SHALL BE COMPLETED DURING THE IN-WATER WORK WINDOW.
3. THE CONTRACTOR MAY NOT LEAVE THE WORK SITE OR SUSPEND ACTIVITY FOR MORE THAN FIVE (5) CONSECUTIVE DAYS AFTER MOBILIZING TO THE SITE AND PRIOR TO REACHING SUBSTANTIAL COMPLETION UNLESS OTHERWISE APPROVED BY THE CONTRACTING OFFICER.
4. THE NORMAL WORK HOURS SHALL BE 7:00 AM TO 5:00 PM, MONDAY THROUGH FRIDAY. NO WORK SHALL BE PERFORMED AT THE SITE OUTSIDE THE NORMAL WORK HOURS, OR ON SATURDAYS, SUNDAYS, OR HOLIDAYS UNLESS AUTHORIZED BY THE CONTRACTING OFFICER. THE CONTRACTOR SHALL REQUEST WORK HOUR VARIATIONS IN WRITING VIA EMAIL FROM THE CONTRACTING OFFICER PRIOR TO WORKING OUTSIDE NORMAL WORK HOURS.

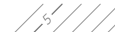

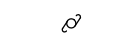





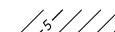
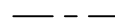
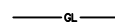

**SITE LOCATION**

1. ALL WORK IS ON THE METHOW RIVER, ASSOCIATED FLOODPLAIN, AND UPLAND AREAS. THE PROJECT IS LOCATED ON PRIVATE AND PUBLIC LAND: SECTION 3, TOWNSHIP 34 NORTH, RANGE 21 EAST, OKANOGAN COUNTY, WASHINGTON.
2. CONSTRUCTION ACCESS TO THE RIVER WILL BE IDENTIFIED BY THE CONTRACTING OFFICER. SITE IMPROVEMENTS MAY BE REQUIRED TO CREATE ACCESS POINTS SUITABLE FOR MOBILIZATION OF CONSTRUCTION EQUIPMENT AND DELIVERY OF PROJECT MATERIALS.

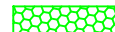
**EXISTING CONDITIONS LEGEND**

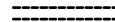
	PROPERTY LINE, APPROXIMATE
	EXISTING CONTOUR (1-FT INTERVAL)
	EXISTING ACCESS ROAD
	EXISTING OVERHEAD POWER LINE
	POWER POLE
	EXISTING CHANNEL
	ORDINARY HIGH WATER (OHW)
	EXISTING RIP RAP
	EXISTING CATEGORY 3 WETLAND

**PROPOSED CONDITIONS LEGEND**

	PROPOSED CONTOUR (1-FT INTERVAL)
	CHANNEL THALWEG
	GRADING LIMIT
	PROPOSED INUNDATION (LOW FLOW - 131 CFS)
	POOL EXCAVATION
	WOOD HABITAT STRUCTURE
	CONSTRUCTED RIFFLE
	FILL (COARSE NATIVE ALLUVIUM)
	SHORT ROUGHENED EDGE
	TEMPORARY ACCESS ROUTE
	TEMPORARY COFFERDAM
	SPOILS AREA
	TEMPORARY MATERIAL STOCKPILE AREA
	TEMPORARY STAGING AND REFUELING AREA

**ABBREVIATIONS**

AC	ACRE
BMP	BEST MANAGEMENT PRACTICES
BO	BIOLOGICAL OPINION
BPA	BONNEVILLE POWER ADMINISTRATION
CFS	CUBIC FEET PER SECOND
CO/C.O.	CONTRACTING OFFICER
CP	CONTROL POINT
CSRO	COLUMBIA-SNAKE SALMON RECOVERY OFFICE
CWA	CLEAN WATER ACT
CY	CUBIC YARDS
DBH	DIAMETER AT BREAST HEIGHT
DEQ	DEPARTMENT OF ENVIRONMENTAL QUALITY
DSL	DEPARTMENT OF STATE LANDS
EA	EACH
E	EAST
EG	EXISTING GROUND
EL	ELEVATION
EPA	ENVIRONMENTAL PROTECTION AGENCY
ESA	ENDANGERED SPECIES ACT
FCRPS	FEDERAL COLUMBIA RIVER POWER SYSTEM
FG	FINISH GRADE
HIP	HABITAT IMPROVEMENT PROGRAM
HWY	HIGHWAY
I	INTERSTATE
LWD	LARGE WOODY DEBRIS
LWM	LARGE WOODY MATERIAL
MC	MAIN CHANNEL
MW	MONITORING WELL
N	NORTH
NAD	NORTH AMERICAN DATUM
NAVD	NORTH AMERICAN VERTICAL DATUM
NEPA	NATIONAL ENVIRONMENTAL POLICY ACT
NMFS	NATIONAL MARINE FISHERIES SERVICE
NPDES	NATIONAL POLLUTION DISCHARGE ELIMINATION SYSTEM
OC	ON CENTER
OG	ORIGINAL GRADE
OHW	ORDINARY HIGH WATER
OSHA	OCCUPATIONAL SAFETY AND HEALTH ADMINISTRATION
PH	PHONE
PLS	PURE LIVE SEED
PLS/AC	PURE LIVE SEED PER ACRE
PP	PLAN AND PROFILE
R	RANGE
REM	RELATIVE ELEVATION MODEL
S	SOUTH
SC	SIDE CHANNEL
SEC.	SECTION
SHPO	STATE HISTORIC PRESERVATION OFFICE
STA	STATION
SWPPP	STORM WATER POLLUTION PREVENTION PLAN
SY	SQUARE YARDS
T	TOWNSHIP
TESC	TEMPORARY EROSION & SEDIMENT CONTROL
TOB	TOP OF BANK
TYP	TYPICAL
U.G.	UNITED STATES
USACE	UNITED STATES ARMY CORPS OF ENGINEERS
USBR	UNITED STATE BUREAU OF RECLAMATION
USFS	UNITED STATES FOREST SERVICE
USFWS	UNITED STATES FISH & WILDLIFE SERVICE
V	VOLTS
W	WEST
WDFW	WASHINGTON DEPARTMENT OF FISH AND WILDLIFE
WSE	WATER SURFACE ELEVATION
YR	YEAR



**METHOW RIVER FOGHORN REACH RESTORATION PROJECT PHASE 1 FINAL DESIGN DRAWINGS**  
 FOR: YAKAMA NATION FISHERIES  
 METHOW RIVER - FOGHORN REACH  
 OKANOGAN COUNTY, WASHINGTON



DATE: APRIL 3, 2026  
 DESIGNED: TDS, SJB  
 APPROVED: JCY

DRAWING NAME  
**GENERALS**  
  
 GENERAL NOTES 1

DRAWING NO.  
**G2**  
 SHEET 2 OF 19

FILE: R:\PROJECTS\METHOW\_RIVER\PROJECTS\METHOW\_RIVER\RESTORATION - YALC\DWG\PRODUCTION\FOGHORN\_GENERAL.DWG SAVED BY: TIM SICKLES PLOT DATE: 4/2/2026 12:35 PM

**HIP IV CONSERVATION MEASURES APPLICABLE TO ALL ACTIONS**

THE ACTIVITIES COVERED HERE ARE INTENDED TO PROTECT AND RESTORE FISH AND WILDLIFE HABITAT WITH LONG-TERM BENEFITS TO ESA-LISTED SPECIES. THE FOLLOWING GENERAL CONSERVATION MEASURES (DEVELOPED IN COORDINATION WITH USFWS AND NMFS) WILL BE APPLIED TO ALL ACTIONS OF THIS PROJECT.

**PROJECT DESIGN AND SITE PREPARATION.**

**1. STATE AND FEDERAL PERMITS.**

- A. ALL APPLICABLE REGULATORY PERMITS AND OFFICIAL PROJECT AUTHORIZATIONS WILL BE OBTAINED BEFORE PROJECT IMPLEMENTATION.
B. THESE PERMITS AND AUTHORIZATIONS INCLUDE, BUT ARE NOT LIMITED TO, NATIONAL ENVIRONMENTAL POLICY ACT, NATIONAL HISTORIC PRESERVATION ACT, THE APPROPRIATE STATE AGENCY REMOVAL AND FILL PERMIT, USACE CLEAN WATER ACT (CWA) 404 PERMITS, CWA SECTION 401 WATER QUALITY CERTIFICATIONS, AND FEMA NO-RISE ANALYSES.

**2. TIMING OF IN-WATER WORK.**

- A. APPROPRIATE STATE (OREGON DEPARTMENT OF FISH AND WILDLIFE (ODFW), WASHINGTON DEPARTMENT OF FISH AND WILDLIFE (WDFW), IDAHO DEPARTMENT OF FISH AND GAME (IDFG), AND MONTANA FISH WILDLIFE AND PARKS (MFWP)) GUIDELINES FOR TIMING OF IN-WATER WORK WINDOWS (IWW) WILL BE FOLLOWED.
B. CHANGES TO ESTABLISHED WORK WINDOWS WILL BE APPROVED BY REGIONAL STATE BIOLOGISTS.
C. BULL TROUT. FOR AREAS WITH DESIGNATED IN-WATER WORK WINDOWS FOR BULL TROUT OR AREAS KNOWN TO HAVE BULL TROUT, PROJECT PROPONENTS WILL CONTACT THE APPROPRIATE USFWS FIELD OFFICE TO INSURE THAT ALL REASONABLE IMPLEMENTATION MEASURES ARE CONSIDERED AND AN APPROPRIATE IN-WATER WORK WINDOW IS BEING USED TO MINIMIZE PROJECT EFFECTS.
D. LAMPREY. WORKING IN STREAM OR RIVER CHANNELS THAT CONTAIN PACIFIC LAMPREY WILL BE AVOIDED FROM MARCH 1 TO JULY 1 FOR REACHES <5,000 FEET IN ELEVATION AND FROM MARCH 1 TO AUGUST 1 FOR REACHES >5,000 FEET. IF EITHER TIMEFRAME IS INCOMPATIBLE WITH OTHER OBJECTIVES, THE AREA WILL BE SURVEYED FOR NESTS AND LAMPREY PRESENCE, AND AVOIDED IF POSSIBLE. IF LAMPREYS ARE KNOWN TO EXIST, THE PROJECT SPONSOR WILL UTILIZE DEWATERING AND SALVAGE PROCEDURES (SEE FISH SALVAGE AND ELECTROFISHING SECTIONS) TO MINIMIZE ADVERSE EFFECTS.
E. THE IN-WATER WORK WINDOW WILL BE PROVIDED IN THE CONSTRUCTION PLANS.

**3. CONTAMINANTS.**

- A. EXCAVATION OF MORE THAN 20 CUBIC YARDS WILL REQUIRE A SITE VISIT AND DOCUMENTED ASSESSMENT FOR POTENTIAL CONTAMINANT SOURCES. THE SITE ASSESSMENT WILL BE STORED WITH PROJECT FILES OR AS AN APPENDIX TO THE BASIS OF DESIGN REPORT.
B. THE SITE ASSESSMENT WILL SUMMARIZE:
1. THE SITE VISIT, CONDITION OF THE PROPERTY, AND IDENTIFICATION OF ANY AREAS USED FOR VARIOUS INDUSTRIAL PROCESSES;
2. AVAILABLE RECORDS, SUCH AS FORMER SITE USE, BUILDING PLANS, AND RECORDS OF ANY PRIOR CONTAMINATION EVENTS;
3. INTERVIEWS WITH KNOWLEDGEABLE PEOPLE, SUCH AS SITE OWNERS, OPERATORS, OCCUPANTS, NEIGHBORS, OR LOCAL GOVERNMENT OFFICIALS; AND
4. THE TYPE, QUANTITY, AND EXTENT OF ANY POTENTIAL CONTAMINATION SOURCES.

**4. SITE LAYOUT AND FLAGGING.**

- A. CONSTRUCTION AREAS TO BE CLEARLY FLAGGED PRIOR TO CONSTRUCTION.
B. AREAS TO BE FLAGGED WILL INCLUDE:
1. SENSITIVE RESOURCE AREAS, SUCH AS AREAS BELOW ORDINARY HIGH WATER, SPAWNING AREAS, SPRINGS, AND WETLANDS;
2. EQUIPMENT ENTRY AND EXIT POINTS;
3. ROAD AND STREAM CROSSING ALIGNMENTS;
4. STAGING, STORAGE, AND STOCKPILE AREAS; AND
5. NO-SPRAY AREAS AND BUFFERS.

**5. TEMPORARY ACCESS ROADS AND PATHS.**

- A. EXISTING ACCESS ROADS AND PATHS WILL BE PREFERENTIALLY USED WHENEVER REASONABLE, AND THE NUMBER AND LENGTH OF TEMPORARY ACCESS ROADS AND PATHS THROUGH RIPARIAN AREAS AND FLOODPLAINS WILL BE MINIMIZED.
B. VEHICLE USE AND HUMAN ACTIVITIES, INCLUDING WALKING, IN AREAS OCCUPIED BY TERRESTRIAL ESA-LISTED SPECIES WILL BE MINIMIZED.
C. TEMPORARY ACCESS ROADS AND PATHS WILL NOT BE BUILT ON SLOPES WHERE GRADE, SOIL, OR OTHER FEATURES SUGGEST A LIKELIHOOD OF EXCESSIVE EROSION OR FAILURE. IF SLOPES ARE STEEPER THAN 30%, THEN THE ROAD WILL BE DESIGNED BY A CIVIL ENGINEER WITH EXPERIENCE IN STEEP ROAD DESIGN.
D. THE REMOVAL OF RIPARIAN VEGETATION DURING CONSTRUCTION OF TEMPORARY ACCESS ROADS WILL BE MINIMIZED. WHEN TEMPORARY VEGETATION REMOVAL IS REQUIRED, VEGETATION WILL BE CUT AT GROUND LEVEL (NOT GRUBBED).
E. AT PROJECT COMPLETION, ALL TEMPORARY ACCESS ROADS AND PATHS WILL BE OBLITERATED, AND THE

SOIL WILL BE STABILIZED AND REVEGETATED. ROAD AND PATH OBLITERATION REFERS TO THE MOST COMPREHENSIVE DEGREE OF DECOMMISSIONING AND INVOLVES DECOMPACTING THE SURFACE AND DITCH, PULLING THE FILL MATERIAL ONTO THE RUNNING SURFACE, AND RESHAPING TO MATCH THE ORIGINAL CONTOUR.

- F. HELICOPTER FLIGHT PATTERNS WILL BE ESTABLISHED IN ADVANCE AND LOCATED TO AVOID TERRESTRIAL ESA-LISTED SPECIES AND THEIR OCCUPIED HABITAT DURING SENSITIVE LIFE STAGES.

**6. TEMPORARY STREAM CROSSINGS.**

- A. EXISTING STREAM CROSSINGS WILL BE PREFERENTIALLY USED WHENEVER REASONABLE, AND THE NUMBER OF TEMPORARY STREAM CROSSINGS WILL BE MINIMIZED.
B. TEMPORARY BRIDGES AND CULVERTS WILL BE INSTALLED TO ALLOW FOR EQUIPMENT AND VEHICLE CROSSING OVER PERENNIAL STREAMS DURING CONSTRUCTION. TREATED WOOD SHALL NOT BE USED ON TEMPORARY BRIDGE CROSSINGS OR IN LOCATIONS IN CONTACT WITH OR DIRECTLY OVER WATER.
C. FOR PROJECTS THAT REQUIRE EQUIPMENT AND VEHICLES TO CROSS IN THE WET:
1. THE LOCATION AND NUMBER OF ALL WET CROSSINGS SHALL BE APPROVED BY THE PROJECT SPONSOR AND DOCUMENTED IN THE CONSTRUCTION PLANS;
2. VEHICLES AND MACHINERY SHALL CROSS STREAMS AT RIGHT ANGLES TO THE MAIN CHANNEL WHENEVER POSSIBLE;
3. NO STREAM CROSSINGS WILL OCCUR 300 FEET UPSTREAM OR 100 FEET DOWNSTREAM OF AN EXISTING REDD OR SPAWNING FISH; AND
4. AFTER PROJECT COMPLETION, TEMPORARY STREAM CROSSINGS WILL BE OBLITERATED AND BANKS RESTORED.

**7. STAGING, STORAGE, AND STOCKPILE AREAS.**

- A. STAGING AREAS (USED FOR CONSTRUCTION EQUIPMENT STORAGE, VEHICLE STORAGE, FUELING, SERVICING, AND HAZARDOUS MATERIAL STORAGE) WILL BE 150 FEET OR MORE FROM ANY NATURAL WATER BODY OR WETLAND. STAGING AREAS CLOSER THAN 150 FEET WILL BE APPROVED BY THE EC LEAD.
B. NATURAL MATERIALS USED FOR IMPLEMENTATION OF AQUATIC RESTORATION, SUCH AS LARGE WOOD, GRAVEL, AND BOULDERS, MAY BE STAGED WITHIN 150 FEET IF CLEARLY INDICATED IN THE PLANS THAT AREA IS FOR NATURAL MATERIALS ONLY.
C. ANY LARGE WOOD, TOPSOIL, AND NATIVE CHANNEL MATERIAL DISPLACED BY CONSTRUCTION WILL BE STOCKPILED FOR USE DURING SITE RESTORATION AT A SPECIFICALLY IDENTIFIED AND FLAGGED AREA.
D. ANY MATERIAL NOT USED IN RESTORATION, AND NOT NATIVE TO THE FLOODPLAIN, WILL BE DISPOSED OF OUTSIDE THE 100-YEAR FLOODPLAIN.

**8. EQUIPMENT.**

- A. MECHANIZED EQUIPMENT AND VEHICLES WILL BE SELECTED, OPERATED, AND MAINTAINED IN A MANNER THAT MINIMIZES ADVERSE EFFECTS ON THE ENVIRONMENT (E.G., MINIMALLY-SIZED, LOW PRESSURE TIRES; MINIMAL HARD-TURN PATHS FOR TRACKED VEHICLES; TEMPORARY MATS OR PLATES WITHIN WET AREAS OR ON SENSITIVE SOILS).
B. EQUIPMENT WILL BE STORED, FUELED, AND MAINTAINED IN AN CLEARLY IDENTIFIED STAGING AREA THAT MEETS STAGING AREA CONSERVATION MEASURES;
C. EQUIPMENT WILL BE REFUELED IN A VEHICLE STAGING AREA OR IN AN ISOLATED HARD ZONE, SUCH AS A PAVED PARKING LOT OR ADJACENT, ESTABLISHED ROAD (THIS MEASURE APPLIES ONLY TO GAS-POWERED EQUIPMENT WITH TANKS LARGER THAN 5 GALLONS);
D. BIODEGRADABLE LUBRICANTS AND FLUIDS WILL BE USED ON EQUIPMENT OPERATING IN AND ADJACENT TO THE STREAM CHANNEL AND LIVE WATER.
E. EQUIPMENT WILL BE INSPECTED DAILY FOR FLUID LEAKS BEFORE LEAVING THE VEHICLE STAGING AREA FOR OPERATION WITHIN 150 FEET OF ANY NATURAL WATER BODY OR WETLAND; AND
F. EQUIPMENT WILL BE THOROUGHLY CLEANED BEFORE OPERATION BELOW ORDINARY HIGH WATER, AND AS OFTEN AS NECESSARY DURING OPERATION, TO REMAIN GREASE FREE.

**9. EROSION CONTROL.**

- A. TEMPORARY EROSION CONTROL MEASURES INCLUDE:
1. TEMPORARY EROSION CONTROLS WILL BE IN PLACE BEFORE ANY SIGNIFICANT ALTERATION OF THE ACTION SITE AND APPROPRIATELY INSTALLED DOWNSLOPE OF PROJECT ACTIVITY WITHIN THE RIPARIAN BUFFER AREA UNTIL SITE REHABILITATION IS COMPLETE;
2. IF THERE IS A POTENTIAL FOR ERODED SEDIMENT TO ENTER THE STREAM, SEDIMENT BARRIERS WILL BE INSTALLED AND MAINTAINED FOR THE DURATION OF PROJECT IMPLEMENTATION;
3. TEMPORARY EROSION CONTROL MEASURES MAY INCLUDE SEDGE MATS, FIBER WATTLES, SILT FENCES, JUTE MATTING, WOOD FIBER MULCH AND SOIL BINDER, OR GEOTEXTILES AND GEOSYNTHETIC FABRIC;
4. SOIL STABILIZATION UTILIZING WOOD FIBER MULCH AND TACKIFIER (HYDRO-APPLIED) MAY BE USED TO REDUCE EROSION OF BARE SOIL IF THE MATERIALS ARE NOXIOUS WEED FREE AND NONTOXIC TO AQUATIC AND TERRESTRIAL ANIMALS, SOIL MICROORGANISMS, AND VEGETATION;
5. SEDIMENT WILL BE REMOVED FROM EROSION CONTROLS ONCE IT HAS REACHED 1/3 OF THE EXPOSED HEIGHT OF THE CONTROL; AND
6. ONCE THE SITE IS STABILIZED AFTER CONSTRUCTION, TEMPORARY EROSION CONTROL MEASURES WILL BE REMOVED.

- B. EMERGENCY EROSION CONTROLS. THE FOLLOWING MATERIALS FOR EMERGENCY EROSION CONTROL

WILL BE AVAILABLE AT THE WORK SITE:

- 1. A SUPPLY OF SEDIMENT CONTROL MATERIALS; AND
2. AN OIL-ABSORBING FLOATING BOOM WHENEVER SURFACE WATER IS PRESENT.

**10. DUST ABATEMENT.**

- A. THE PROJECT SPONSOR WILL DETERMINE THE APPROPRIATE DUST CONTROL MEASURES BY CONSIDERING SOIL TYPE, EQUIPMENT USAGE, PREVAILING WIND DIRECTION, AND THE EFFECTS CAUSED BY OTHER EROSION AND SEDIMENT CONTROL MEASURES.
B. WORK WILL BE SEQUENCED AND SCHEDULED TO REDUCE EXPOSED BARE SOIL SUBJECT TO WIND EROSION.
C. DUST-ABATEMENT ADDITIVES AND STABILIZATION CHEMICALS (TYPICALLY MAGNESIUM CHLORIDE, CALCIUM CHLORIDE SALTS, OR LIGNINSULFONATE) WILL NOT BE APPLIED WITHIN 25 FEET OF WATER OR A STREAM CHANNEL AND WILL BE APPLIED SO AS TO MINIMIZE THE LIKELIHOOD THAT THEY WILL ENTER STREAMS. APPLICATIONS OF LIGNINSULFONATE WILL BE LIMITED TO A MAXIMUM RATE OF 0.5 GALLONS PER SQUARE YARD OF ROAD SURFACE, ASSUMING MIXED 50:50 WITH WATER.
D. APPLICATION OF DUST ABATEMENT CHEMICALS WILL BE AVOIDED DURING OR JUST BEFORE WET WEATHER, AND AT STREAM CROSSINGS OR OTHER AREAS THAT COULD RESULT IN UNFILTERED DELIVERY OF THE DUST ABATEMENT MATERIALS TO A WATERBODY (TYPICALLY THESE WOULD BE AREAS WITHIN 25 FEET OF A WATERBODY OR STREAM CHANNEL; DISTANCES MAY BE GREATER WHERE VEGETATION IS SPARSE OR SLOPES ARE STEEP).
E. SPILL CONTAINMENT EQUIPMENT WILL BE AVAILABLE DURING APPLICATION OF DUST ABATEMENT CHEMICALS.
F. PETROLEUM-BASED PRODUCTS WILL NOT BE USED FOR DUST ABATEMENT.

**11. SPILL PREVENTION, CONTROL, AND COUNTER MEASURES.**

- A. A DESCRIPTION OF HAZARDOUS MATERIALS THAT WILL BE USED, INCLUDING INVENTORY, STORAGE, AND HANDLING PROCEDURES WILL BE AVAILABLE ON-SITE.
B. WRITTEN PROCEDURES FOR NOTIFYING ENVIRONMENTAL RESPONSE AGENCIES WILL BE POSTED AT THE WORK SITE.
C. SPILL CONTAINMENT KITS (INCLUDING INSTRUCTIONS FOR CLEANUP AND DISPOSAL) ADEQUATE FOR THE TYPES AND QUANTITY OF HAZARDOUS MATERIALS USED AT THE SITE WILL BE AVAILABLE AT THE WORK SITE.
D. WORKERS WILL BE TRAINED IN SPILL CONTAINMENT PROCEDURES AND WILL BE INFORMED OF THE LOCATION OF SPILL CONTAINMENT KITS.
E. ANY WASTE LIQUIDS GENERATED AT THE STAGING AREAS WILL BE TEMPORARILY STORED UNDER AN IMPERVIOUS COVER, SUCH AS A TARPULIN, UNTIL THEY CAN BE PROPERLY TRANSPORTED TO AND DISPOSED OF AT A FACILITY THAT IS APPROVED FOR RECEIPT OF HAZARDOUS MATERIALS.
F. PUMPS USED ADJACENT TO WATER SHALL USE SPILL CONTAINMENT SYSTEMS.

**12. INVASIVE SPECIES CONTROL.**

- A. PRIOR TO ENTERING THE SITE, ALL VEHICLES AND EQUIPMENT WILL BE POWER WASHED, ALLOWED TO FULLY DRY, AND INSPECTED TO MAKE SURE NO PLANTS, SOIL, OR OTHER ORGANIC MATERIAL ADHERES TO THE SURFACE.
B. WATERCRAFT, WADERS, BOOTS, AND ANY OTHER GEAR TO BE USED IN OR NEAR WATER WILL BE INSPECTED FOR AQUATIC INVASIVE SPECIES.
C. WADING BOOTS WITH FELT SOLES ARE NOT TO BE USED DUE TO THEIR PROPENSITY FOR AIDING IN THE TRANSFER OF INVASIVE SPECIES UNLESS DECONTAMINATION PROCEDURES HAVE BEEN APPROVED BY THE PROJECT SPONSOR.



METHOW RIVER FOGHORN REACH RESTORATION PROJECT PHASE 1 FINAL DESIGN DRAWINGS FOR: YAKAMA NATION FISHERIES METHOW RIVER - FOGHORN REACH OKANOGAN COUNTY, WASHINGTON



DATE: APRIL 3, 2026
DESIGNED: TDS, SJB
APPROVED: JCY

DRAWING NAME
GENERALS
HIP CONSERVATION MEASURES 1

DRAWING NO.
G3
SHEET 3 OF 19

FILE: R:\PROJECTS\METHOW\_HIP\CD\PRODUCTION\FOGHORN\_REACH\_RESTORATION\_GENERAL.DWG SAVED BY: TIM SICKLES PLOT DATE: 4/2/2026 12:35 PM

**WORK AREA ISOLATION AND FISH SALVAGE.**

**1. WORK AREA ISOLATION.**

- A. ANY WORK AREA WITHIN THE WETTED CHANNEL WILL BE ISOLATED FROM THE ACTIVE STREAM WHENEVER ESA-LISTED FISH ARE REASONABLY CERTAIN TO BE PRESENT, OR IF THE WORK AREA IS LESS THAN 300-FEET UPSTREAM FROM KNOWN SPAWNING HABITATS.
- B. WORK AREA ISOLATION AND FISH SALVAGE ACTIVITIES WILL COMPLY WITH THE IN-WATER WORK WINDOW.
- C. DESIGN PLANS WILL INCLUDE ALL ISOLATION ELEMENTS AND AREAS (COFFER DAMS, PUMPS, DISCHARGE AREAS, FISH SCREENS, FISH RELEASE AREAS, ETC.).
- D. WORK AREA ISOLATION AND FISH CAPTURE ACTIVITIES WILL OCCUR DURING PERIODS OF THE COOLEST AIR AND WATER TEMPERATURES POSSIBLE, NORMALLY EARLY IN THE MORNING VERSUS LATE IN THE DAY, AND DURING CONDITIONS APPROPRIATE TO MINIMIZE STRESS AND DEATH OF SPECIES PRESENT.

**2. FISH SALVAGE.**

- A. MONITORING AND RECORDING WILL TAKE PLACE FOR DURATION OF SALVAGE. THE SALVAGE REPORT WILL BE COMMUNICATED TO AGENCIES VIA THE PROJECT COMPLETION FORM (PCF).
- B. SALVAGE ACTIVITIES SHOULD TAKE PLACE DURING CONDITIONS TO MINIMIZE STRESS TO FISH SPECIES, TYPICALLY PERIODS OF THE COOLEST AIR AND WATER TEMPERATURES WHICH OCCUR IN THE MORNING VERSUS LATE IN THE DAY.
- C. SALVAGE OPERATIONS WILL FOLLOW THE ORDERING, METHODOLOGIES, AND CONSERVATION MEASURES SPECIFIED BELOW:
  - 1. SLOWLY REDUCE WATER FROM THE WORK AREA TO ALLOW SOME FISH TO LEAVE VOLITIONALLY.
  - 2. BLOCK NETS WILL BE INSTALLED AT UPSTREAM AND DOWNSTREAM LOCATIONS AND MAINTAINED IN A SECURED POSITION TO EXCLUDE FISH FROM ENTERING THE PROJECT AREA.
  - 3. BLOCK NETS WILL BE SECURED TO THE STREAM CHANNEL BED AND BANKS UNTIL FISH CAPTURE AND TRANSPORT ACTIVITIES ARE COMPLETE. BLOCK NETS MAY BE LEFT IN PLACE FOR THE DURATION OF THE PROJECT TO EXCLUDE FISH AS LONG AS PASSAGE REQUIREMENTS ARE MET.
  - 4. NETS WILL BE MONITORED HOURLY DURING IN-STREAM DISTURBANCE.
  - 5. IF BLOCK NETS REMAIN IN PLACE MORE THAN ONE DAY, THE NETS WILL BE MONITORED AT LEAST DAILY TO ENSURE THEY ARE SECURED AND FREE OF ORGANIC ACCUMULATION. IF BULL TROUT ARE PRESENT, NETS ARE TO BE CHECKED EVERY 4 HOURS FOR FISH IMPINGEMENT.
  - 6. CAPTURE FISH THROUGH SEINING AND RELOCATE TO STREAMS.
  - 7. WHILE DEWATERING, ANY REMAINING FISH WILL BE COLLECTED BY HAND OR DIP NETS.
  - 8. SEINES WITH A MESH SIZE TO ENSURE CAPTURE OF THE RESIDING ESA-LISTED FISH WILL BE USED.
  - 9. MINNOW TRAPS WILL BE LEFT IN PLACE OVERNIGHT AND USED IN CONJUNCTION WITH SEINING.
  - 10. ELECTROFISH TO CAPTURE AND RELOCATED FISH NOT CAUGHT DURING SEINING PER ELECTROFISH CONSERVATION MEASURES.
  - 11. CONTINUE TO SLOWLY DEWATER STREAM REACH.
  - 12. COLLECT ANY REMAINING FISH IN COLD-WATER BUCKETS AND RELOCATED TO THE STREAM.
  - 13. LIMIT THE TIME FISH ARE IN A TRANSPORT BUCKET.
  - 14. MINIMIZE PREDATION BY TRANSPORTING COMPARABLE SIZES IN BUCKETS.
  - 15. BUCKET WATER TO BE CHANGED EVERY 15 MINUTES OR AERATED.
  - 16. BUCKETS WILL BE KEPT IN SHADED AREAS OR COVERED.
  - 17. DEAD FISH WILL NOT BE STORED IN TRANSPORT BUCKETS, BUT WILL BE LEFT ON THE STREAM BANK TO AVOID MORTALITY COUNTING ERRORS.
- D. SALVAGE GUIDELINES FOR BULL TROUT, LAMPREY, MUSSELS, AND NATIVE FISH.
  - 1. CONDUCT SITE SURVEY TO ESTIMATE SALVAGE NUMBERS.
  - 2. PRE-SELECT SITE(S) FOR RELEASE AND/OR MUSSEL BED RELOCATION.
  - 3. SALVAGE OF BULL TROUT WILL NOT TAKE PLACE WHEN WATER TEMPERATURES EXCEED 15 DEGREES CELSIUS.
  - 4. IF DRAWDOWN LESS THAN 48 HOURS, SALVAGE OF LAMPREY AND MUSSELS MAY NOT BE NECESSARY IF TEMPERATURES SUPPORT SURVIVAL IN SEDIMENTS.
  - 5. SALVAGE MUSSELS BY HAND, LOCATING BY SNORKELING OR WADING.
  - 6. SALVAGE LAMPREY BY ELECTROFISHING (SEE ELECTROFISHING FOR LARVAL LAMPREY SETTINGS AND LARVAL LAMPREY DRY SHOCKING SETTINGS).
  - 7. SALVAGE BONY FISH AFTER LAMPREY WITH NETS OR ELECTROFISHING (SEE ELECTROFISHING FOR APPROPRIATE SETTINGS).
  - 8. REGULARLY INSPECT DEWATERED SITE SINCE LAMPREY LIKELY TO EMERGE AFTER DEWATERING AND MUSSELS MAY BECOME VISIBLE.
  - 9. MUSSELS MAY BE TRANSFERRED IN COOLERS.
  - 10. MUSSELS WILL BE PLACED INDIVIDUALLY TO ENSURE ABILITY TO BURROW INTO NEW HABITAT.

**3. ELECTROFISHING.**

- A. INITIAL SITE SURVEY AND INITIAL SETTINGS.
  - 1. IDENTIFY SPAWNING ADULTS AND ACTIVE REDDS TO AVOID.
  - 2. RECORD WATER TEMPERATURE. ELECTROFISHING WILL NOT OCCUR WHEN WATER TEMPERATURES ARE ABOVE 18 DEGREES CELSIUS.
  - 3. IF POSSIBLE, A BLOCK NET WILL BE PLACED DOWNSTREAM AND CHECKED REGULARLY TO CAPTURE STUNNED FISH THAT DRIFT DOWNSTREAM.
  - 4. INITIAL SETTINGS WILL BE 100 VOLTS, PULSE WIDTH OF 500 MICRO SECONDS, AND PULSE RATE OF 30 HERTZ.
  - 5. RECORDS FOR CONDUCTIVITY, WATER TEMPERATURE, AIR TEMPERATURE, ELECTROFISHING SETTINGS, ELECTROFISHER MODEL, ELECTROFISHER CALIBRATION, FISH CONDITIONS, FISH MORTALITIES, AND TOTAL CAPTURE RATES WILL BE INCLUDED IN THE SALVAGE LOG BOOK.
- B. ELECTROFISHING TECHNIQUE.
  - 1. SAMPLING WILL BEGIN USING STRAIGHT DC. POWER WILL REMAIN ON UNTIL THE FISH IS NETTED WHEN USING STRAIGHT DC. GRADUALLY INCREASE VOLTAGE WHILE REMAINING BELOW MAXIMUM LEVELS.
  - 2. MAXIMUM VOLTAGE WILL BE 1100 VOLTS WHEN CONDUCTIVITY IS <100 MILLISECONDS, 800 VOLTS WHEN CONDUCTIVITY IS BETWEEN 100 AND 300 MILLISECONDS, AND 400 VOLTS WHEN CONDUCTIVITY IS >300 MILLISECONDS.
  - 3. IF FISH CAPTURE IS NOT SUCCESSFUL USING STRAIGHT DC, THE ELECTROFISHER WILL BE SET TO INITIAL VOLTAGE FOR PDC. VOLTAGE, PULSE WIDTH, AND PULSE FREQUENCY WILL BE GRADUALLY INCREASED WITHIN MAXIMUM VALUES UNTIL CAPTURE IS SUCCESSFUL.
  - 4. MAXIMUM PULSE WIDTH IS 5 MILLISECONDS. MAXIMUM PULSE RATE IS 70 HERTZ
  - 5. ELECTROFISHING WILL NOT OCCUR IN ONE AREA FOR AN EXTENDED PERIOD.
  - 6. THE ANODE WILL NOT INTENTIONALLY COME INTO CONTACT WITH FISH. THE ZONE FOR POTENTIAL INJURY OF 0.5 M FROM THE ANODE WILL BE AVOIDED.
  - 7. SETTINGS WILL BE LOWERED IN SHALLOWER WATER SINCE VOLTAGE GRADIENTS LIKELY TO INCREASE.
  - 8. ELECTROFISHING WILL NOT OCCUR IN TURBID WATER WHERE VISIBILITY IS POOR (I.E. UNABLE TO SEE THE BED OF THE STREAM).
  - 9. OPERATIONS WILL IMMEDIATELY STOP IF MORTALITY OR OBVIOUS FISH INJURY IS OBSERVED. ELECTROFISHING SETTINGS WILL BE REEVALUATED.
- C. SAMPLE PROCESSING.
  - 1. FISH SHOULD BE SORTED BY SIZE TO AVOID PREDATION DURING SAMPLING.
  - 2. SAMPLERS WILL REGULARLY CHECK CONDITIONS OF FISH HOLDING CONTAINERS, AIR PUMPS, WATER TRANSFERS, ETC.
  - 3. FISH WILL BE OBSERVED FOR GENERAL CONDITIONS AND INJURIES
  - 4. EACH FISH WILL BE COMPLETELY REVIVED BEFORE RELEASE. ESA-LISTED SPECIES WILL BE PRIORITIZED FOR SUCCESSFUL RELEASE.
- D. BULL TROUT ELECTROFISHING.
  - 1. ELECTROFISHING FOR BULL TROUT WILL ONLY OCCUR FROM MAY 1 TO JULY 31. NO ELECTROFISHING WILL OCCUR IN ANY BULL TROUT OCCUPIED HABITAT AFTER AUGUST 15. IN FMO HABITATS ELECTROFISHING MAY OCCUR ANY TIME.
  - 2. ELECTROFISHING OF BULL TROUT WILL NOT OCCUR WHEN WATER TEMPERATURES EXCEED 15 DEGREES CELSIUS.
- E. LARVAL LAMPREY ELECTROFISHING.
  - 1. PERMISSION FROM PROJECT SPONSOR WILL BE OBTAINED IF LARVAL LAMPREY ELECTROFISHER IS NOT ONE OF FOLLOWING PRE-APPROVED MODELS: ABP-2 "WISCONSIN", SMITH-ROOT LR-24, OR SMITH-ROOT APEX BACKPACK.
  - 2. LARVAL LAMPREY SAMPLING WILL INCORPORATE 2-STAGE METHOD: "TICKLE" AND "STUN".
  - 3. FIRST STAGE: USE 125 VOLT DC WITH A 25 PERCENT DUTY CYCLE APPLIED AT A SLOW RATE OF 3 PULSES PER SECOND. IF TEMPERATURES ARE BELOW 10 DEGREES CELSIUS, VOLTAGE MAY BE INCREASED GRADUALLY (NOT TO EXCEED 200 VOLTS). BURSTED PULSES (THREE SLOW AND ONE SKIPPED) RECOMMENDED TO INCREASE EMERGENCE.
  - 4. SECOND STAGE (OPTIONAL FOR EXPERIENCED NETTERS): IMMEDIATELY AFTER LAMPREY EMERGE, USE A FAST PULSE SETTING OF 30 PULSES PER SECOND.
  - 5. USE DIP NETS FOR VISIBLE LAMPREY. SIENES AND FINE MESH NET SWEEPS MAY BE USED IN POOR VISIBILITY.
  - 6. SAMPLING WILL OCCUR SLOWLY (>60 SECONDS PER METER) STARTING AT UPSTREAM AND WORKING DOWNSTREAM.
  - 7. MULTIPLE SWEEPS TO OCCUR WITH 15 MINUTES BETWEEN SWEEPS.
  - 8. POST-DRAWDOWN "DRY-SHOCKING" WILL BE APPLIED IF LARVAL LAMPREY CONTINUE TO EMERGE. ANODES TO BE PLACED ONE METER APART TO SAMPLE ONE SQUARE METER AT A TIME FOR AT LEAST 60 SECONDS. FOR TEMPERATURES LESS THAN 10 DEGREES CELSIUS, MAXIMUM VOLTAGE MAY BE GRADUALLY INCREASED TO 400 VOLTS (DRY-SHOCKING ONLY).

**4. DEWATERING.**

- A. DEWATERING WILL OCCUR AT A RATE SLOW ENOUGH TO ALLOW SPECIES TO NATURALLY MIGRATE OUT OF THE WORK AREA.
- B. WHERE A GRAVITY FEED DIVERSION IS NOT POSSIBLE, A PUMP MAY BE USED. PUMPS WILL BE INSTALLED TO AVOID REPETITIVE DEWATERING AND REWATERING.
- C. WHEN FISH ARE PRESENT, PUMPS WILL BE SCREENED IN ACCORDANCE WITH NMFS FISH SCREEN CRITERIA. NMFS ENGINEERING REVIEW AND APPROVAL WILL BE OBTAINED FOR PUMPS EXCEEDING 3 CUBIC FEET PER SECOND.
- D. DISSIPATION OF FLOW ENERGY AT THE BYPASS OUTFLOW WILL BE PROVIDED TO PREVENT DAMAGE TO THE STREAM CHANNEL AND RIPARIAN VEGETATION.
- E. SEEPAGE WATER WILL BE PUMPED TO A TEMPORARY STORAGE AND TREATMENT SITE OF INTO UPLAND AREAS TO ALLOW WATER TO PERCOLATE THROUGH SOIL AND VEGETATION PRIOR TO REENTERING THE STREAM CHANNEL.



**METHOW RIVER FOGHORN REACH RESTORATION PROJECT PHASE 1 FINAL DESIGN DRAWINGS**  
 FOR: YAKAMA NATION FISHERIES  
 METHOW RIVER - FOGHORN REACH  
 OKANOGAN COUNTY, WASHINGTON



DATE: APRIL 3, 2026  
 DESIGNED: TDS, SJB  
 APPROVED: JCY

DRAWING NAME  
**GENERALS**  
  
**HIP CONSERVATION MEASURES 2**

DRAWING NO.  
**G4**  
 SHEET 4 OF 19

FILE: R:\PROJECTS\METHOW\_HIP\CD\PRODUCTION\FOGHORN\_GENERAL.DWG SAVED BY: TIM SICKLES PLOT DATE: 4/2/2026 12:35 PM



**CONSTRUCTION QUANTITIES**

Item Description	Overall QTY	North Work Area QTY	South Work Area QTY	Unit
<b>General</b>				
Mobilization and Demobilization	1			LS
Environmental Controls	1			LS
*Temporary Construction Access	1			LS
Cofferdams and Dewatering	1			LS
Construction Staking/Surveying	1			LS
<b>Site Work</b>				
Channel Excavation (cut)	386	90	296	CY
General Fill	386	90	296	CY
Constructed Riffle	104		104	CY
Wood Material Acquisition and Delivery	1			LS
HS-1: Three Log Structure	2		2	EA
HS-2: Low Profile Bank Jam	2		2	EA
HS-3: Large Bank Jam	2	2		EA
HS-4: Single Log Structure	10		10	EA
Roughened Edge Bank Treatment	93		93	LF
**Medium Track Hoe (i.e. CAT 330 or similar)	10			HRS

\*TEMPORARY CONSTRUCTION ACCESS INCLUDES ESTABLISHING AND RECLAIMING ACCESS ROUTES INCLUDING RESTORATION OF PRIVATE DRIVEWAYS AND IMPORT OF GRAVEL AS NECESSARY TO RESTORE TO PRE-PROJECT CONDITION.

\*\*OPTIONAL BID ITEM, TO BE PERFORMED AS DIRECTED BY THE CONTRACTING OFFICER.

WOOD MATERIALS SCHEDULE							
MATERIAL TYPE	SIZE (DBH) (IN)	MIN. LENGTH (FT)	ROOTWAD	MIN. ROOTWAD DIA. (FT)	BRANCHES	TOTAL	UNIT
*TYPE 1	18" - 24"	35 - 40	YES	5	NO	24	EA
*TYPE 2	18" - 24"	30 - 35	YES	4.5	NO	21	EA
*TYPE 3	18" - 24"	25 - 30	NO	NA	NO	18	EA
RACKING	6" - 14"	15 - 25	YES	2.5	YES	76	EA
SLASH	1" - 4"	5 - 15	NA	NA	YES	114	CY

\*TYPE 1, 2, AND 3 LOGS ARE SUPPLIED BY THE PROJECT SPONSOR, CONTRACTOR IS RESPONSIBLE FOR TRANSPORTING FROM THE SOURCE TO THE PROJECT SITE.



**METHOW RIVER FOGHORN REACH RESTORATION PROJECT PHASE 1 FINAL DESIGN DRAWINGS**  
 FOR: YAKAMA NATION FISHERIES  
 METHOW RIVER - FOGHORN REACH  
 OKANOGAN COUNTY, WASHINGTON



DATE: APRIL 3, 2026  
 DESIGNED: TDS, SJB  
 APPROVED: JCY

DRAWING NAME  
**GENERALS**  
  
**CONSTRUCTION QUANTITIES**

DRAWING NO.  
**G6**  
 SHEET 6 OF 19

FILE: R:\PROJECTS\METHOW\_HUCS1\FOGHORN\_REACH\_RESTORATION\_YM\CAD\PRODUCTION\FOGHORN\_GENERALS.DWG SAVED BY: TIM SICKLES PLOT DATE: 4/2/2026 11:23 AM



1 LOOKING UPSTREAM AT EXISTING FOGHORN DIVERSION DAM AT UPSTREAM LIMITS OF PROJECT



2 LOOKING UPSTREAM AT EXISTING HIGH-ANGLE RIFFLE DOWNSTREAM OF FOGHORN DIVERSION DAM.



3 LOOKING DOWNSTREAM, EXISTING BEDROCK EXPOSURE ON RIVER RIGHT AT UPSTREAM END OF RIFFLE.



4 LOOKING UPSTREAM TOWARD THE INLET OF AN EXISTING HIGH FLOW SIDE CHANNEL THAT FOLLOWS THE NORTH SIDE OF THE P.U.D. HATCHERY AND TIES INTO THE HATCHERY EFFLUENT CHANNEL DOWNSTREAM.



5 LOOKING UPSTREAM AT THE EXISTING GRAVEL BAR AND HIGH FLOW SIDE CHANNEL INLETS ON THE RIVER RIGHT BANK.



6 LOOKING DOWNSTREAM AT EXISTING GRAVEL BAR AND SEASONAL SIDE CHANNEL ON RIVER RIGHT.



7 LOOKING UPSTREAM AT CONFLUENCE OF P.U.D. EFFLUENT CHANNEL AND METHOW RIVER.



8 LOOKING DOWNSTREAM, EXISTING SEASONAL SIDE CHANNEL INLET AT UPSTREAM END OF GRAVEL BAR.



9 LOOKING DOWNSTREAM AT EXISTING RIFFLE WITH LARGE BOULDERS AND LOW FLOW ALCOVE NEAR DOWNSTREAM PROJECT EXTENTS.

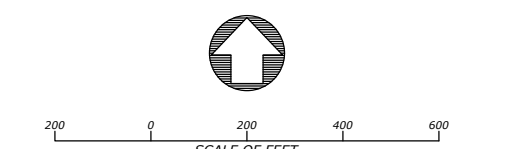

NOTE: HIGH RESOLUTION AERIAL DRONE IMAGERY AND ON-THE GROUND PHOTOS CAPTURED BY RIO ASE OCTOBER 19, 2022.



**METHOW RIVER FOGHORN REACH RESTORATION PROJECT PHASE 1**  
**FINAL DESIGN DRAWINGS**



DATE:	APRIL 3, 2026
DESIGNED:	TDS, SJB
APPROVED:	JCY
DRAWING NAME	EXISTING CONDITIONS
	OVERVIEW
DRAWING NO.	C1
	SHEET 7 OF 19

FILE: R:\PROJECTS\METHOW\_HUCS1\FOGHORN\_REACH\_RESTORATION\_YM\CAD\PRODUCTION\FOGHORN\_EXISTINGOVERVIEW.DWG SAVED BY: TM SICKLES PLOT DATE: 4/2/2026 12:37 PM

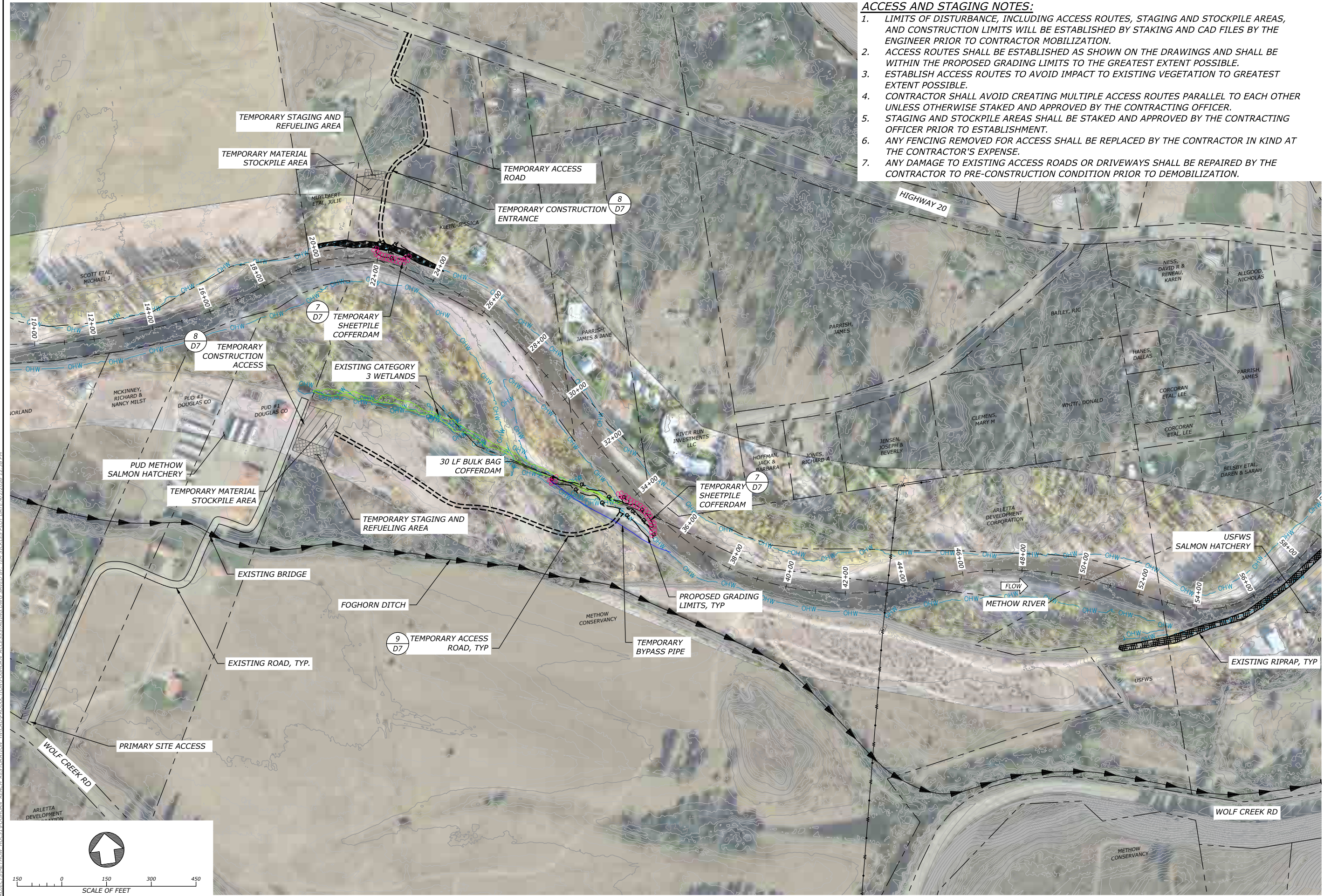

**ACCESS AND STAGING NOTES:**

1. LIMITS OF DISTURBANCE, INCLUDING ACCESS ROUTES, STAGING AND STOCKPILE AREAS, AND CONSTRUCTION LIMITS WILL BE ESTABLISHED BY STAKING AND CAD FILES BY THE ENGINEER PRIOR TO CONTRACTOR MOBILIZATION.
2. ACCESS ROUTES SHALL BE ESTABLISHED AS SHOWN ON THE DRAWINGS AND SHALL BE WITHIN THE PROPOSED GRADING LIMITS TO THE GREATEST EXTENT POSSIBLE.
3. ESTABLISH ACCESS ROUTES TO AVOID IMPACT TO EXISTING VEGETATION TO GREATEST EXTENT POSSIBLE.
4. CONTRACTOR SHALL AVOID CREATING MULTIPLE ACCESS ROUTES PARALLEL TO EACH OTHER UNLESS OTHERWISE STAKED AND APPROVED BY THE CONTRACTING OFFICER.
5. STAGING AND STOCKPILE AREAS SHALL BE STAKED AND APPROVED BY THE CONTRACTING OFFICER PRIOR TO ESTABLISHMENT.
6. ANY FENCING REMOVED FOR ACCESS SHALL BE REPLACED BY THE CONTRACTOR IN KIND AT THE CONTRACTOR'S EXPENSE.
7. ANY DAMAGE TO EXISTING ACCESS ROADS OR DRIVEWAYS SHALL BE REPAIRED BY THE CONTRACTOR TO PRE-CONSTRUCTION CONDITION PRIOR TO DEMOBILIZATION.



**METHOW RIVER FOGHORN REACH RESTORATION PROJECT PHASE 1**

**FINAL DESIGN DRAWINGS**

FOR: YAKAMA NATION FISHERIES  
METHOW RIVER - FOGHORN REACH  
OKANOGAN COUNTY, WASHINGTON



DATE: APRIL 3, 2026  
DESIGNED: TDS, SJB  
APPROVED: JCY

DRAWING NAME  
PROPOSED CONDITIONS

ACCESS AND STAGING

DRAWING NO.  
C2  
SHEET 8 OF 19

FILE: R:\PROJECTS\METHOW\_HUCS1\FOGHORN\_REACH\_RESTORATION\YALCAD\PRODUCTION\FOGHORN\_ACCESS\STAGING.DWG SAVED BY: TIM SICKLES PLOT DATE: 4/2/2026 12:38 PM



METHOW RIVER FOGHORN REACH RESTORATION PROJECT PHASE 1

FINAL DESIGN DRAWINGS

FOR: YAKAMA NATION FISHERIES  
METHOW RIVER - FOGHORN REACH  
OKANOGAN COUNTY, WASHINGTON



DATE: APRIL 3, 2026  
DESIGNED: TDS, SJR  
APPROVED: JCY

DRAWING NAME  
PROPOSED CONDITIONS

CONSTRUCTION SEQUENCING

DRAWING NO.  
C3  
SHEET 9 OF 19

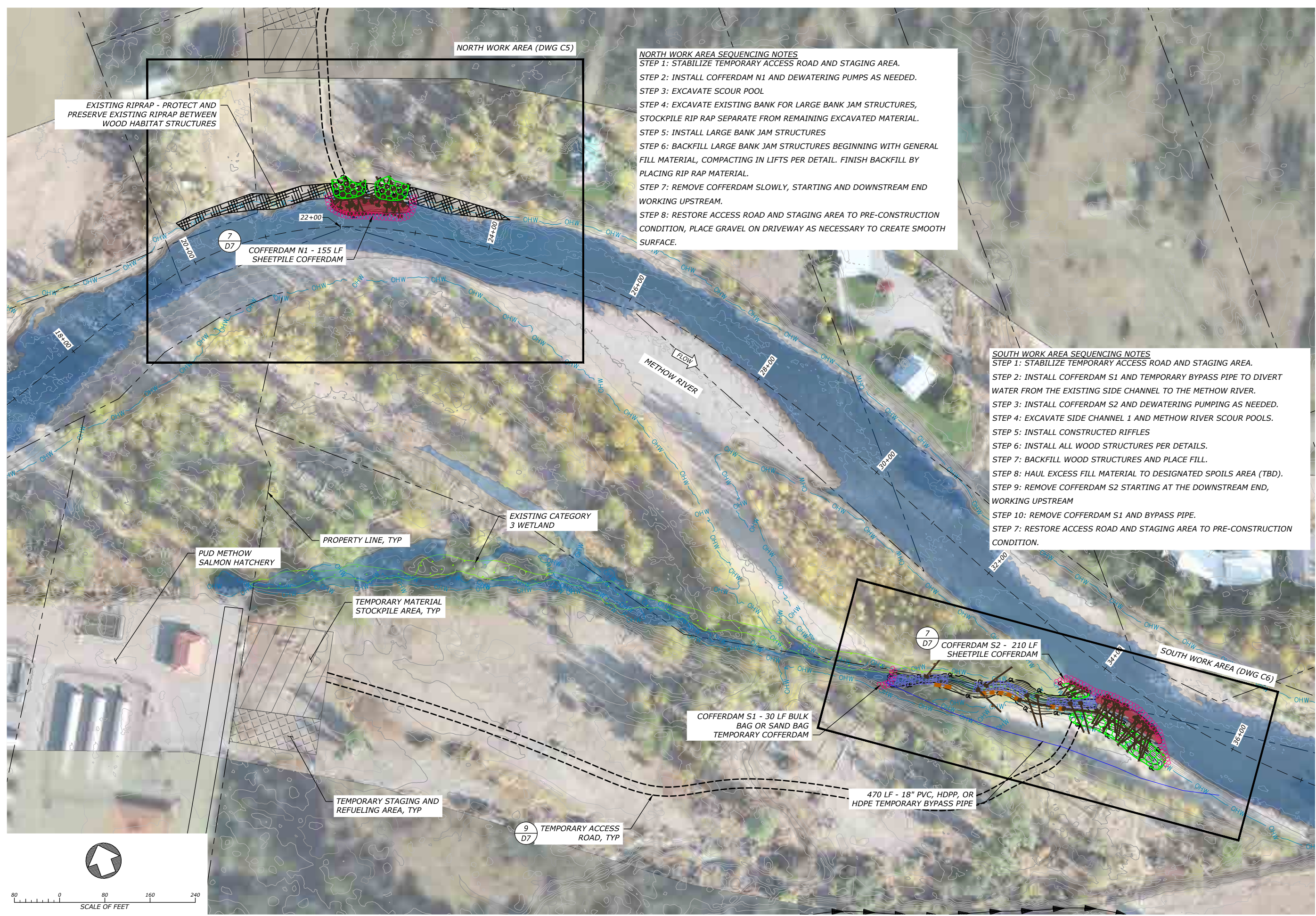

**NORTH WORK AREA SEQUENCING NOTES**  
STEP 1: STABILIZE TEMPORARY ACCESS ROAD AND STAGING AREA.  
STEP 2: INSTALL COFFERDAM N1 AND DEWATERING PUMPS AS NEEDED.  
STEP 3: EXCAVATE SCOUR POOL  
STEP 4: EXCAVATE EXISTING BANK FOR LARGE BANK JAM STRUCTURES, STOCKPILE RIP RAP SEPARATE FROM REMAINING EXCAVATED MATERIAL.  
STEP 5: INSTALL LARGE BANK JAM STRUCTURES  
STEP 6: BACKFILL LARGE BANK JAM STRUCTURES BEGINNING WITH GENERAL FILL MATERIAL, COMPACTING IN LIFTS PER DETAIL. FINISH BACKFILL BY PLACING RIP RAP MATERIAL.  
STEP 7: REMOVE COFFERDAM SLOWLY, STARTING AND DOWNSTREAM END WORKING UPSTREAM.  
STEP 8: RESTORE ACCESS ROAD AND STAGING AREA TO PRE-CONSTRUCTION CONDITION, PLACE GRAVEL ON DRIVEWAY AS NECESSARY TO CREATE SMOOTH SURFACE.

**SOUTH WORK AREA SEQUENCING NOTES**  
STEP 1: STABILIZE TEMPORARY ACCESS ROAD AND STAGING AREA.  
STEP 2: INSTALL COFFERDAM S1 AND TEMPORARY BYPASS PIPE TO DIVERT WATER FROM THE EXISTING SIDE CHANNEL TO THE METHOW RIVER.  
STEP 3: INSTALL COFFERDAM S2 AND DEWATERING PUMPING AS NEEDED.  
STEP 4: EXCAVATE SIDE CHANNEL 1 AND METHOW RIVER SCOUR POOLS.  
STEP 5: INSTALL CONSTRUCTED RIFFLES  
STEP 6: INSTALL ALL WOOD STRUCTURES PER DETAILS.  
STEP 7: BACKFILL WOOD STRUCTURES AND PLACE FILL.  
STEP 8: HAUL EXCESS FILL MATERIAL TO DESIGNATED SPOILS AREA (TBD).  
STEP 9: REMOVE COFFERDAM S2 STARTING AT THE DOWNSTREAM END, WORKING UPSTREAM  
STEP 10: REMOVE COFFERDAM S1 AND BYPASS PIPE.  
STEP 7: RESTORE ACCESS ROAD AND STAGING AREA TO PRE-CONSTRUCTION CONDITION.

PROPOSED CONDITIONS - CONSTRUCTION SEQUENCING

FILE: R:\PROJECTS\METHOW\_RIVER\_RESTORATION\YALCAD\PRODUCTION\FOGHORN\_PROPOSEDCONDITIONS.DWG SAVED BY: TM STICKLES PLOT DATE: 4/2/2026 12:39 PM

FILE: R:\PROJECTS\METHOW\_RIVER RESTORATION - YUKA\DWG\PRODUCTION\FOGHORN\_PROPOSEDCONDITIONS.DWG SAVED BY: TM STICKLES PLOT DATE: 4/2/2026 12:39 PM

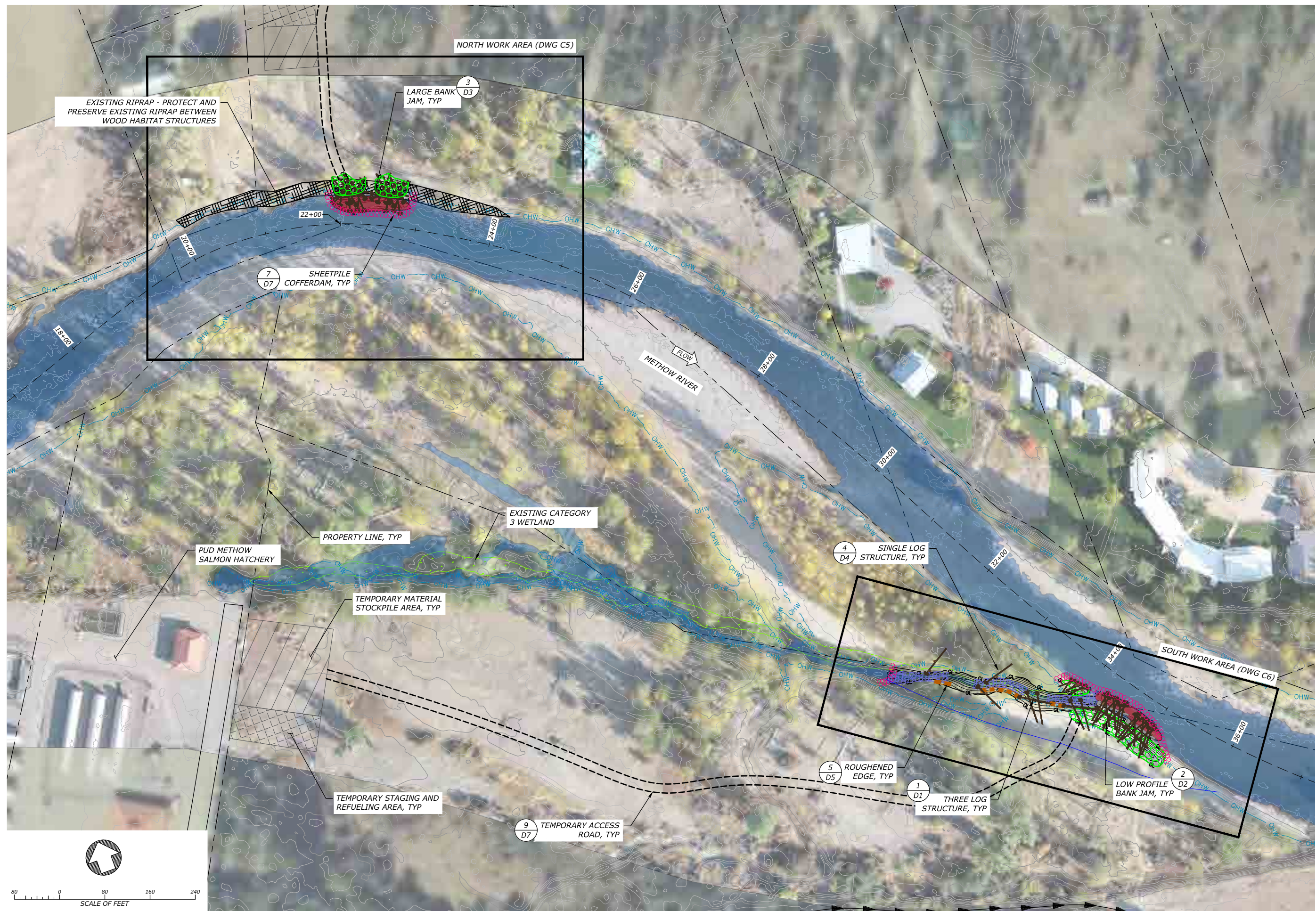

PROPOSED CONDITIONS - OVERVIEW AND KEY MAP



METHOW RIVER FOGHORN REACH RESTORATION PROJECT PHASE 1

FINAL DESIGN DRAWINGS

FOR: YAKAMA NATION FISHERIES  
METHOW RIVER - FOGHORN REACH  
OKANOGAN COUNTY, WASHINGTON



DATE: APRIL 3, 2026  
DESIGNED: TDS, SJB  
APPROVED: JCY

DRAWING NAME  
PROPOSED CONDITIONS

OVERVIEW AND KEY MAP

DRAWING NO.  
C4  
SHEET 10 OF 19





**STRUCTURE SEQUENCING**

**STAGE 1**

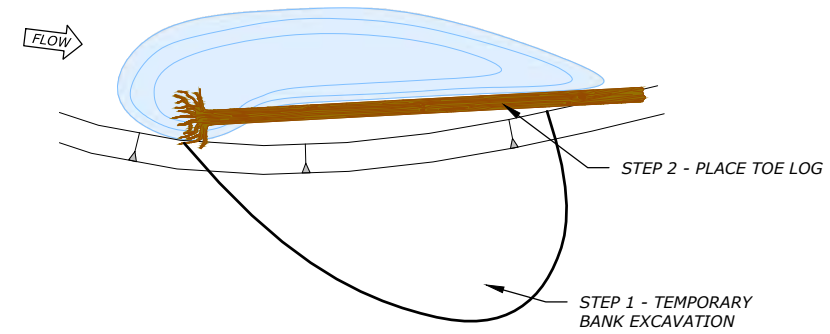

**STAGE 2**

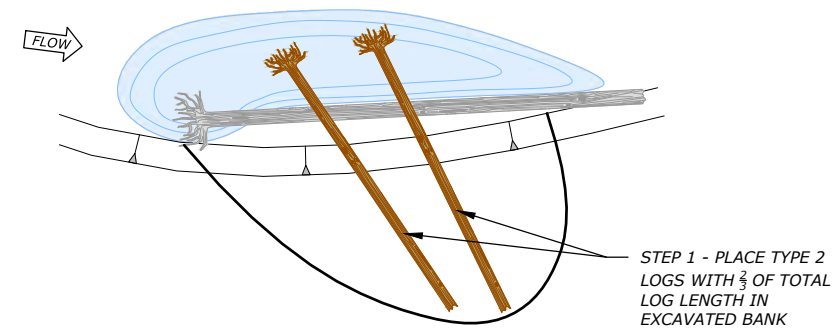

**STAGE 3**

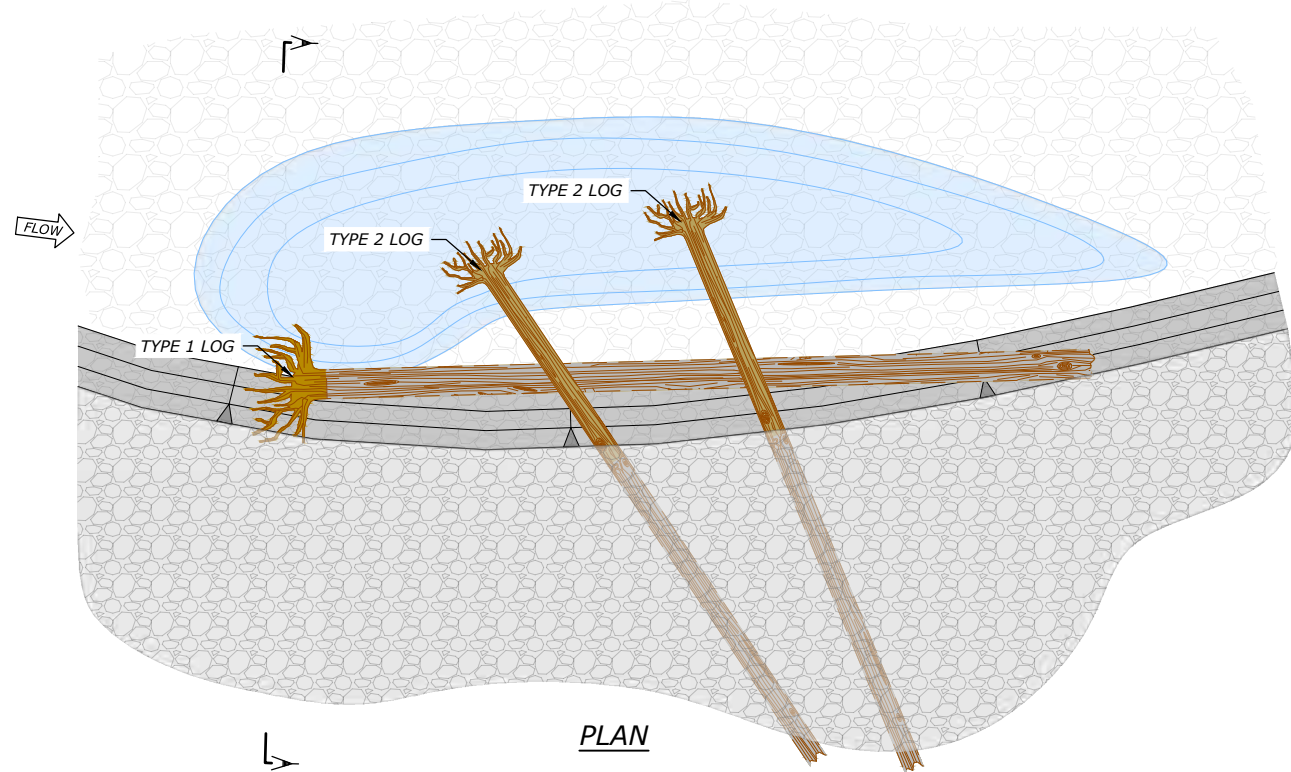
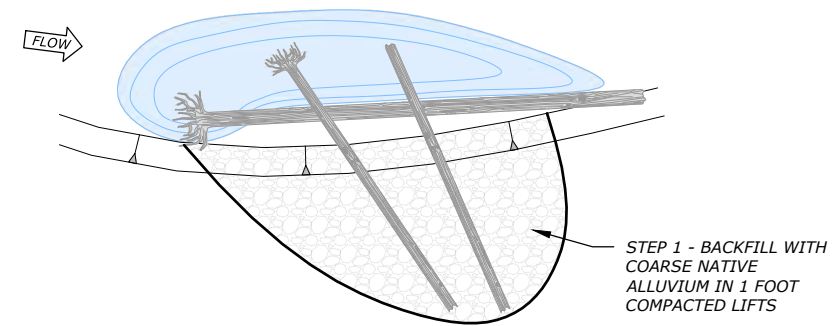

**PLAN**

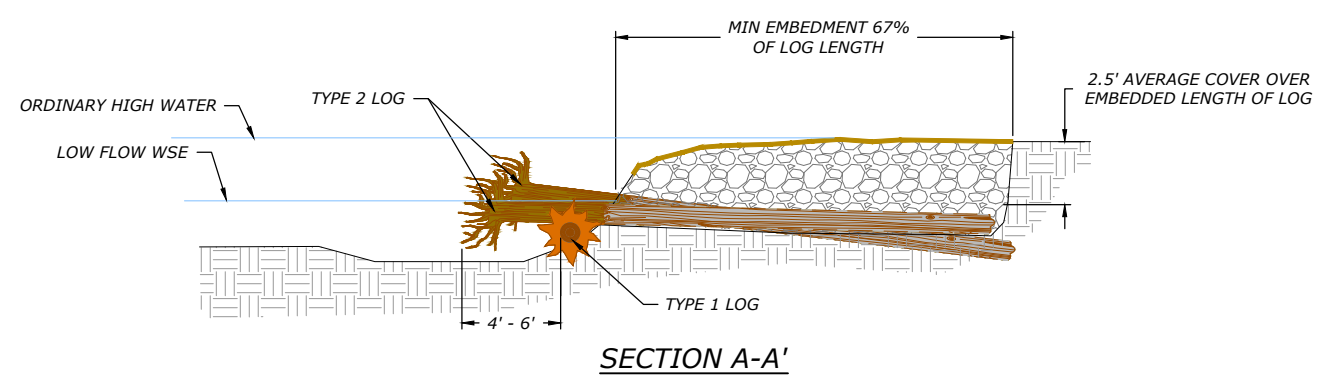

**SECTION A-A'**

**NOTES:**

1. INSTALL STRUCTURES AT LOCATIONS IDENTIFIED IN THE PLANS. THE EXACT LOCATION OF EACH STRUCTURE SHALL BE APPROVED BY THE CONTRACTING OFFICER PRIOR TO INSTALLATION.
2. IF POOL EXCAVATION IS NOT SPECIFIED IN THE GRADING PLAN, THE CONTRACTING OFFICER WILL DETERMINE IF A SCOUR POOL IS DESIRED. THE SCOUR POOL SHALL BE EXCAVATED TO A DEPTH OF 2' ADJACENT TO THE STRUCTURE AND EXTEND BEYOND ROOTWADS EXTENDING INTO CHANNEL PER THE DIRECTION OF THE CONTRACTING OFFICER.
3. ROUGH GRADING OF CHANNEL SHALL BE COMPLETE PRIOR TO CONSTRUCTION OF STRUCTURE INCLUDING CONSTRUCTION OF RIFFLES OR STREAMBED MATERIALS.
4. BACKFILL USING NATIVE EXCAVATED MATERIAL UNLESS NATIVE MATERIAL IS UNSUITABLE. UNSUITABLE IS DEFINED AS ANYTHING CLASSIFIED AS A CLAY, SILT, OR SAND. PLACE BACKFILL IN 1-FOOT MAXIMUM LIFTS. COMPACT EACH LIFT USING MECHANICAL EQUIPMENT SUCH AS AN EXCAVATOR BUCKET OR EQUIPMENT TRACKING MAKING CERTAIN TO NOT DAMAGE OR CHANGE THE ELEVATION OF THE STRUCTURE MATERIAL DURING COMPACTION.
5. ALL CUT ENDS OF LOGS THAT WILL BE EXPOSED UPON COMPLETION OF STRUCTURE SHALL BE MARRED PRIOR TO INSTALLATION. THE CONTRACTOR SHALL USE AN EXCAVATOR, OR OTHER HEAVY EQUIPMENT TO TEAR APART WOOD FIBERS AT THE CUT END OF THE LOG TO CREATE THE APPEARANCE OF A LOG THAT HAS NATURALLY BROKEN APART.
6. LOG PLACEMENT MAY BE ADJUSTED IN THE FIELD BY THE CONTRACTING OFFICER TO PROVIDE VARIABILITY FROM STRUCTURE TO STRUCTURE.

HS-1: Three-Log Structure Material Schedule						
Log Type	Size DBH (in)	Length (ft)	Rootwad	Min. Rootwad Dia. (ft)	Branches	Quantity
Type 1	18 - 24	35 - 42	Yes	5	No	1 EA
Type 2	18 - 24	30 - 35	Yes	4.5	No	2 EA
Slash	1 - 4	5 - 15	NA	NA	Yes	2 CY



**METHOW RIVER FOGHORN REACH RESTORATION PROJECT PHASE 1**  
**FINAL DESIGN DRAWINGS**  
 FOR: YAKAMA NATION FISHERIES  
 METHOW RIVER - FOGHORN REACH  
 OKANOGAN COUNTY, WASHINGTON



DATE: APRIL 3, 2026  
 DESIGNED: TDS, SJB  
 APPROVED: JCY

DRAWING NAME  
**DETAILS**

**HS-1 - THREE LOG STRUCTURE**

DRAWING NO.  
**D1**  
 SHEET 13 OF 19

FILE: R:\PROJECTS\METHOW\_RIVER RESTORATION\YALC\DWG\PRODUCTION\FOGHORN\_DETAILS.DWG SAVED BY: TIM STICKLES PLOT DATE: 4/2/2026 12:41 PM

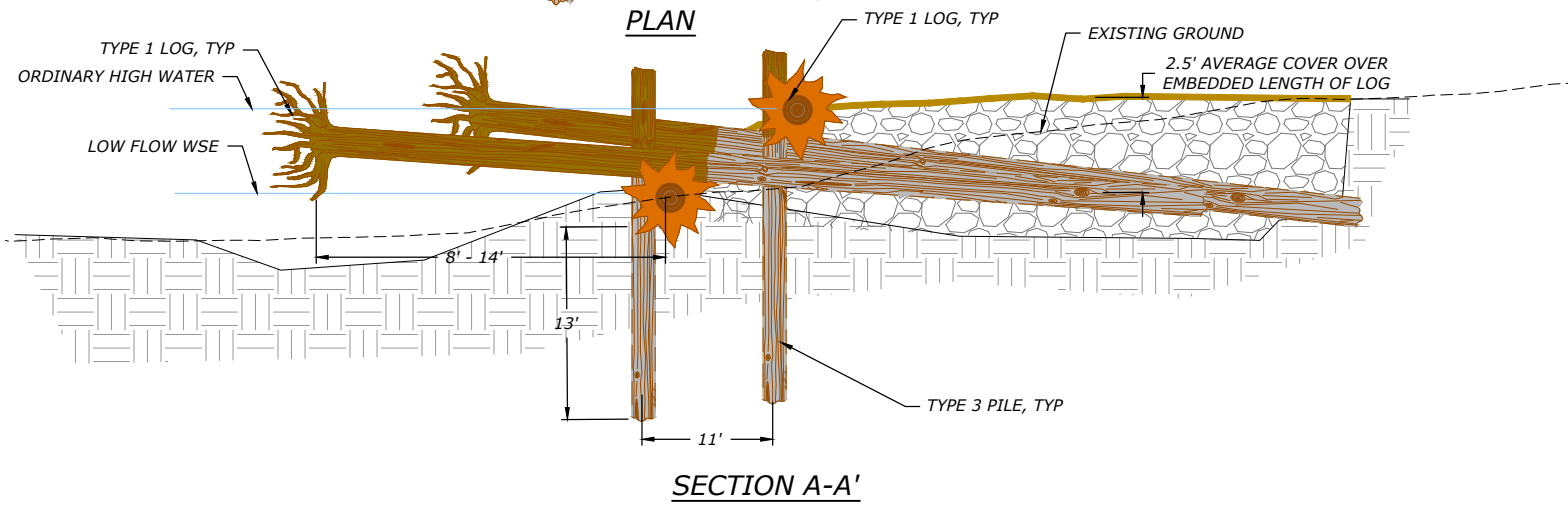
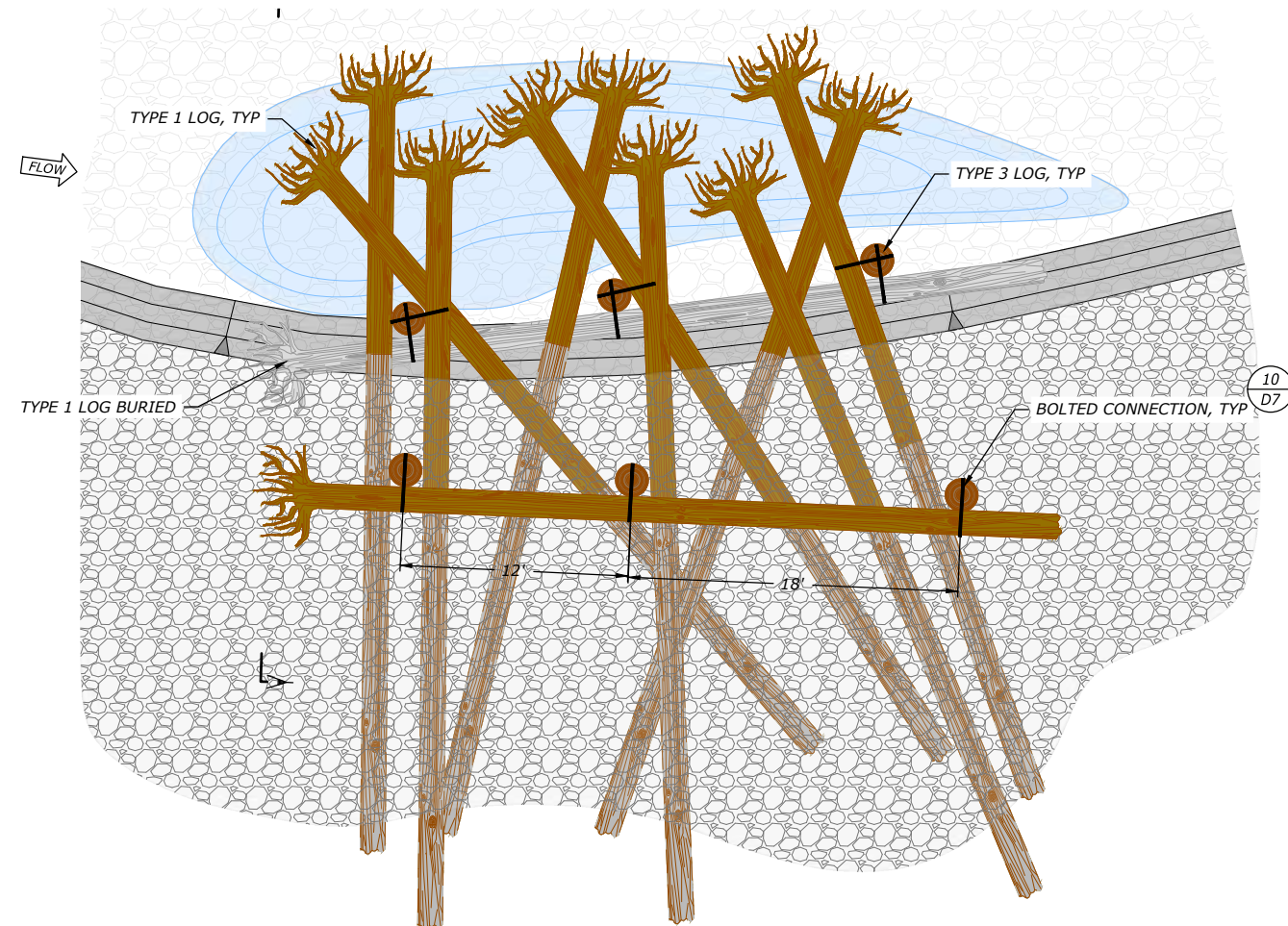

- NOTES:**
1. INSTALL STRUCTURES AT LOCATIONS IDENTIFIED IN THE PLANS. THE EXACT LOCATION OF EACH STRUCTURE SHALL BE APPROVED BY THE CONTRACTING OFFICER PRIOR TO INSTALLATION.
  2. ROUGH GRADING OF CHANNEL AND SCOUR POOLS SHALL BE COMPLETE PRIOR TO CONSTRUCTION OF STRUCTURE INCLUDING CONSTRUCTION OF RIFFLES OR STREAMBED MATERIALS.
  3. PILES SHALL BE VIBRATORY DRIVEN TO MINIMUM DEPTH OF 13'. EXPOSED ENDS OF PILES SHALL BE BROKEN OFF NO MORE THAN 3' ABOVE TOP OF HIGHEST TYPE 1 LOG.
  4. BACKFILL USING NATIVE EXCAVATED MATERIAL UNLESS NATIVE MATERIAL IS UNSUITABLE. UNSUITABLE IS DEFINED AS ANYTHING CLASSIFIED AS A CLAY, SILT, OR SAND. PLACE BACKFILL IN 1-FOOT MAXIMUM LIFTS. COMPACT EACH LIFT USING MECHANICAL EQUIPMENT SUCH AS AN EXCAVATOR BUCKET OR EQUIPMENT TRACKING MAKING CERTAIN TO NOT DAMAGE OR CHANGE THE ELEVATION OF THE STRUCTURE MATERIAL DURING COMPACTION.
  5. ALL CUT ENDS OF LOGS THAT WILL BE EXPOSED UPON COMPLETION OF STRUCTURE SHALL BE MARRED PRIOR TO INSTALLATION. THE CONTRACTOR SHALL USE AN EXCAVATOR, OR OTHER HEAVY EQUIPMENT TO TEAR APART WOOD FIBERS AT THE CUT END OF THE LOG TO CREATE THE APPEARANCE OF A LOG THAT HAS NATURALLY BROKEN APART.
  6. LOG PLACEMENT MAY BE ADJUSTED IN THE FIELD BY THE CONTRACTING OFFICER TO PROVIDE VARIABILITY FROM STRUCTURE TO STRUCTURE.

**STRUCTURE SEQUENCING**

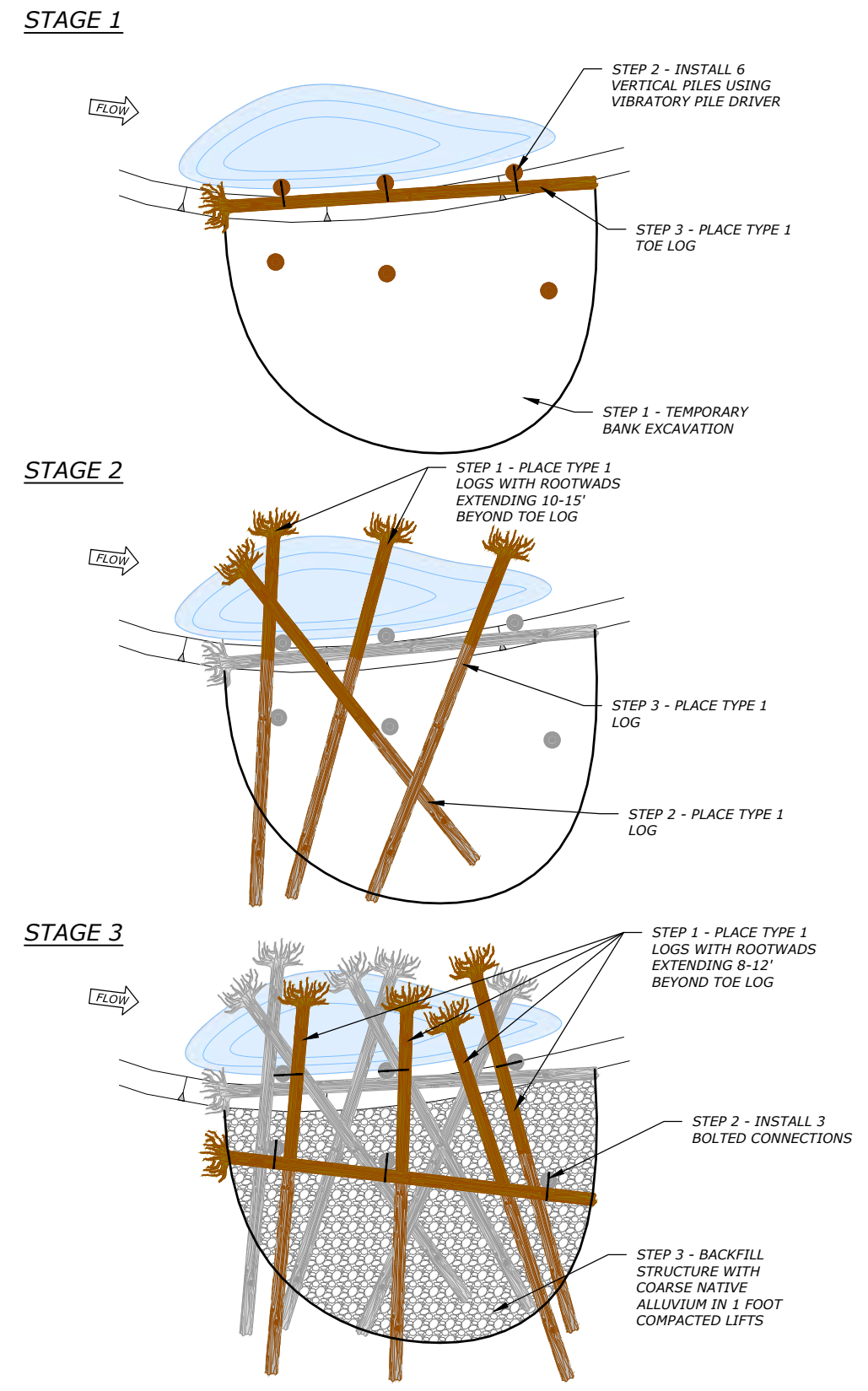

HS-2: Low Profile Bank Jam Material Schedule

Log Type	Size DBH (in)	Length (ft)	Rootwad	Min. Rootwad Dia. (ft)	Branches	Quantity
Type 1	18 - 24	35 - 42	Yes	5	No	11 EA
Type 3	18 - 24	25 - 30	No	NA	No	4 EA
Racking	6 - 14	15 - 25	Yes	2.5	Yes	8 EA
Slash	1 - 4	5 - 15	NA	NA	Yes	5 CY



**METHOW RIVER FOGHORN REACH RESTORATION PROJECT PHASE 1**  
**FINAL DESIGN DRAWINGS**  
 FOR: YAKAMA NATION FISHERIES  
 METHOW RIVER - FOGHORN REACH  
 OKANOGAN COUNTY, WASHINGTON



DATE: APRIL 3, 2026  
 DESIGNED: TDS, SJB  
 APPROVED: JCY

DRAWING NAME  
**DETAILS**  
 HS-2 - LOW PROFILE BANK JAM

DRAWING NO.  
**D2**  
 SHEET 14 OF 19

FILE: R:\PROJECTS\METHOW\_HUCS1\FOGHORN\_REACH\_RESTORATION\_YALCADD\PRODUCTION\FOGHORN\_DETAILS.DWG SAVED BY: TIM STICKLES PLOT DATE: 4/2/2026 12:42 PM

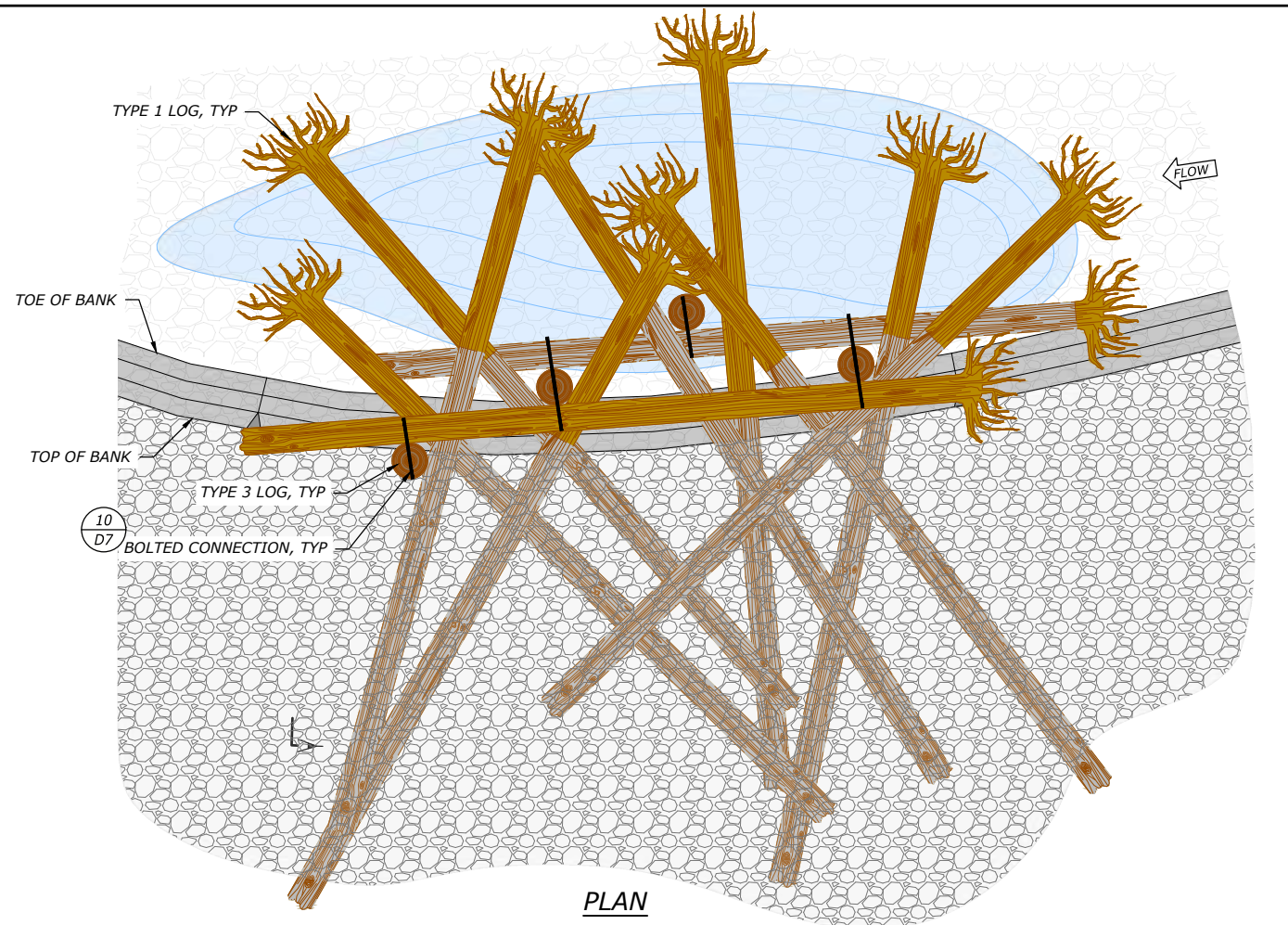

PLAN

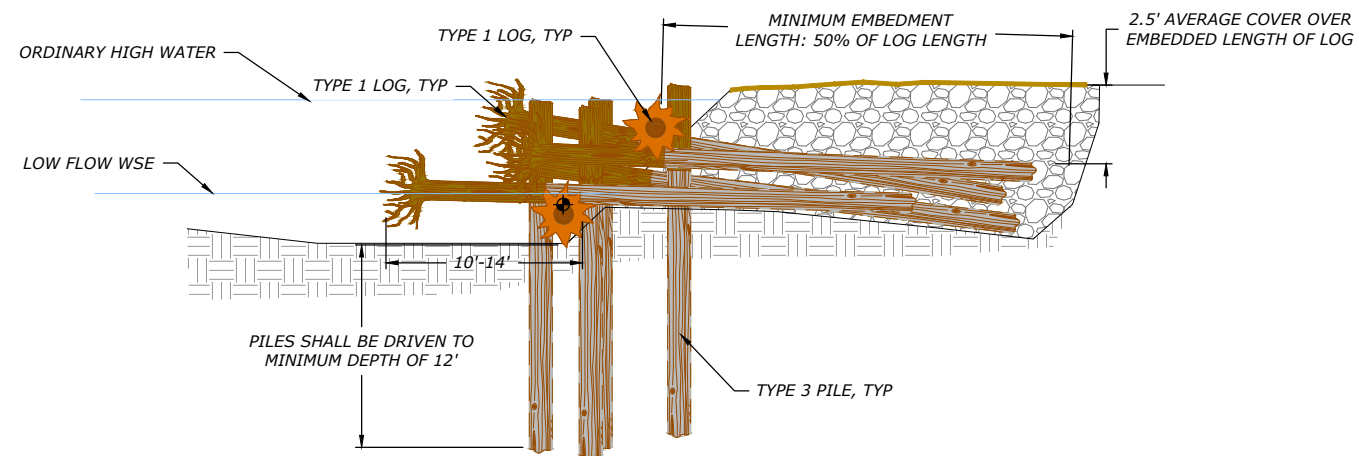

SECTION A-A'

**NOTES:**

1. INSTALL STRUCTURES AT LOCATIONS IDENTIFIED IN THE PLANS. THE EXACT LOCATION OF EACH STRUCTURE SHALL BE APPROVED BY THE CONTRACTING OFFICER PRIOR TO INSTALLATION.
2. IF POOL EXCAVATION IS NOT SPECIFIED IN THE GRADING PLAN, THE CONTRACTING OFFICER WILL DETERMINE IF A SCOUR POOL IS DESIRED. THE SCOUR POOL SHALL BE EXCAVATED TO A DEPTH OF 2' ADJACENT TO THE STRUCTURE AND EXTEND BEYOND ROOTWADS EXTENDING INTO CHANNEL PER THE DIRECTION OF THE CONTRACTING OFFICER.
3. ROUGH GRADING OF CHANNEL SHALL BE COMPLETE PRIOR TO CONSTRUCTION OF STRUCTURE INCLUDING CONSTRUCTION OF RIFFLES OR STREAMBED MATERIALS.
4. BACKFILL USING NATIVE EXCAVATED MATERIAL UNLESS NATIVE MATERIAL IS UNSUITABLE. UNSUITABLE IS DEFINED AS ANYTHING CLASSIFIED AS A CLAY, SILT, OR SAND. PLACE BACKFILL IN 1-FOOT MAXIMUM LIFTS. COMPACT EACH LIFT USING MECHANICAL EQUIPMENT SUCH AS AN EXCAVATOR BUCKET OR EQUIPMENT TRACKING MAKING CERTAIN TO NOT DAMAGE OR CHANGE THE ELEVATION OF THE STRUCTURE MATERIAL DURING COMPACTION.
5. ALL CUT ENDS OF LOGS THAT WILL BE EXPOSED UPON COMPLETION OF STRUCTURE SHALL BE MARRED PRIOR TO INSTALLATION. THE CONTRACTOR SHALL USE AN EXCAVATOR, OR OTHER HEAVY EQUIPMENT TO TEAR APART WOOD FIBERS AT THE CUT END OF THE LOG TO CREATE THE APPEARANCE OF A LOG THAT HAS NATURALLY BROKEN APART.
6. LOG PLACEMENT MAY BE ADJUSTED IN THE FIELD BY THE CONTRACTING OFFICER TO PROVIDE VARIABILITY FROM STRUCTURE TO STRUCTURE.

**STRUCTURE SEQUENCING**

**STAGE 1**

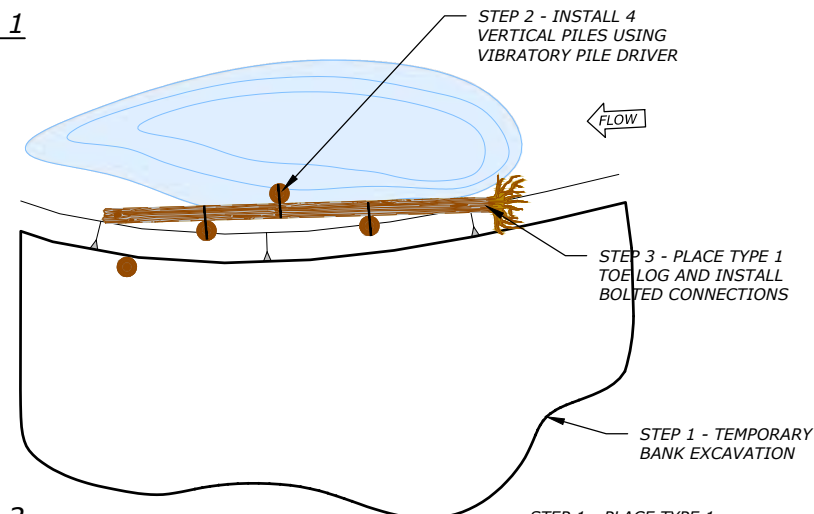

**STAGE 2**

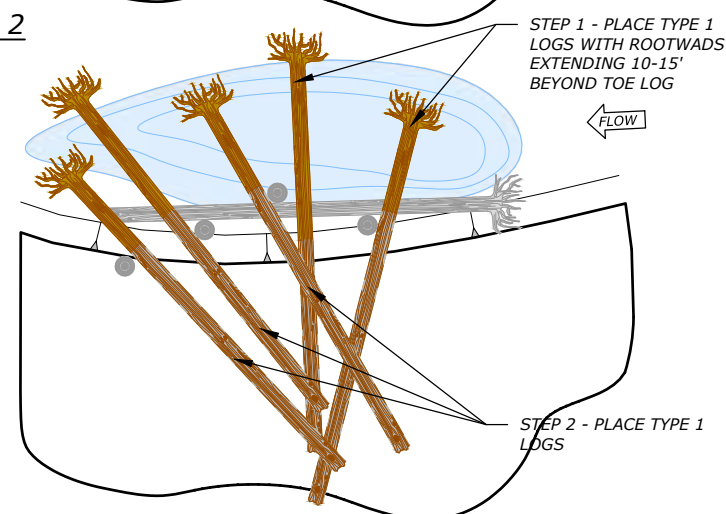

**STAGE 3**

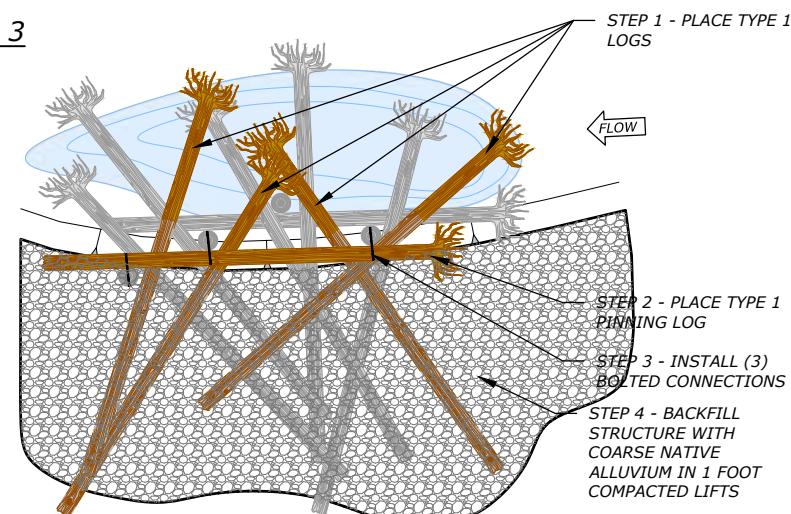

HS-3: Large Bank Jam Material Schedule

Log Type	Size DBH (in)	Length (ft)	Rootwad	Min. Rootwad Dia. (ft)	Branches	Quantity
Type 1	18 - 24	35 - 42	Yes	5	No	11 EA
Racking	6 - 14	15 - 25	Yes	2.5	Yes	12 EA
Slash	1 - 4	5 - 15	NA	NA	Yes	5 CY



METHOW RIVER FOGHORN REACH RESTORATION PROJECT PHASE 1

FINAL DESIGN DRAWINGS

FOR: YAKAMA NATION FISHERIES  
METHOW RIVER - FOGHORN REACH  
OKANOGAN COUNTY, WASHINGTON



DATE: APRIL 3, 2026  
DESIGNED: TDS, SJB  
APPROVED: JCY

DRAWING NAME

DETAILS

HS-3 - LARGE BANK JAM

DRAWING NO.

D3

SHEET 15 OF 19



**ROUGHENED EDGE STRUCTURE SEQUENCING**

STAGE 1

STAGE 2

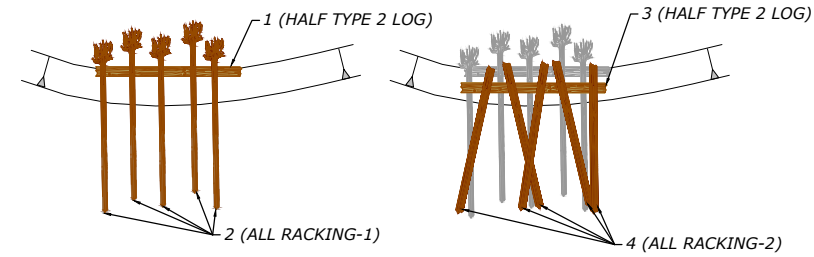

**STEPS:**

1. TYPE 2 LOG (FOOTER) SHALL BE PLACED SO ITS UPSTREAM END RESTS ON THE STREAM BED (UP TO 1/2 DIAMETER BURIED TO ACCOMMODATE VARIED BANK HEIGHTS) ALONG THE TOE OF THE BANK. BACKFILL AND COMPACT AROUND FOOTER LOG WITH COMPACTED FILL.
2. RACKING-2 LOGS (WITH ROOTWADS) SHALL BE INSTALLED ON TOP OF THE TYPE 2 LOG. ROOTWADS SHALL BE PLACED OVER TOP OF FOOTER LOG WITH ROOTWAD AS CLOSE TO BANK AS POSSIBLE AND AS DIRECTED BY C.O.
3. PLACE GENERAL FILL OVER PLACED MATERIALS AND COMPACT TO CREATE AN APPROXIMATE 45-DEGREE SURFACE FOR INSTALLATION OF BRUSH BANK TREATMENT AT THE ANTICIPATED LOW WATER ELEVATION. LOW WATER ELEVATION CAN BE ESTIMATED FROM PLAN AND PROFILE DRAWINGS. A PROPOSED LOW WATER ELEVATION SURFACE CAN BE PROVIDED TO THE CONTRACTOR UPON REQUEST FOR GPS USE.
4. PLACE RACKING LOGS PARALLEL TO BANK AND ALONG BANK AT TOP OF STRUCTURE, PIN WITH TWO RACKING LOGS WITH EXPOSED ENDS DOWNSTREAM TO FLOW. ENSURE THAT RACKING LOGS ARE NOT TOO STEEPLY VERTICALLY ANGLED FROM FRONT TO BACK BY PLACING FILL AT BACKSIDE AS NECESSARY.
5. BACKFILL TO TOP OF ANGLED LOGS WITH COMPACTED FILL.
6. PLACE SLASH ALONG TOP OF BACKFILL AT BANK EDGE AS DIRECTED BY C.O.
7. BACKFILL TO FINISH. BACKFILL SHALL BE PLACED IN MAXIMUM 1-FT LIFTS AND COMPACTED.

Roughened Edge Bank Treatment (Per 15-ft Length) Material Schedule						
Log Type	Size DBH (in)	Length (ft)	Rootwad	Min. Rootwad Dia. (ft)	Branches	Quantity
Type 2	18 - 24	30 - 35	Yes	4.5	No	1 EA
Racking	6 - 14	15 - 25	Yes	2.5	Yes	9 EA
Slash	1 - 4	5 - 15	NA	NA	Yes	15 CY

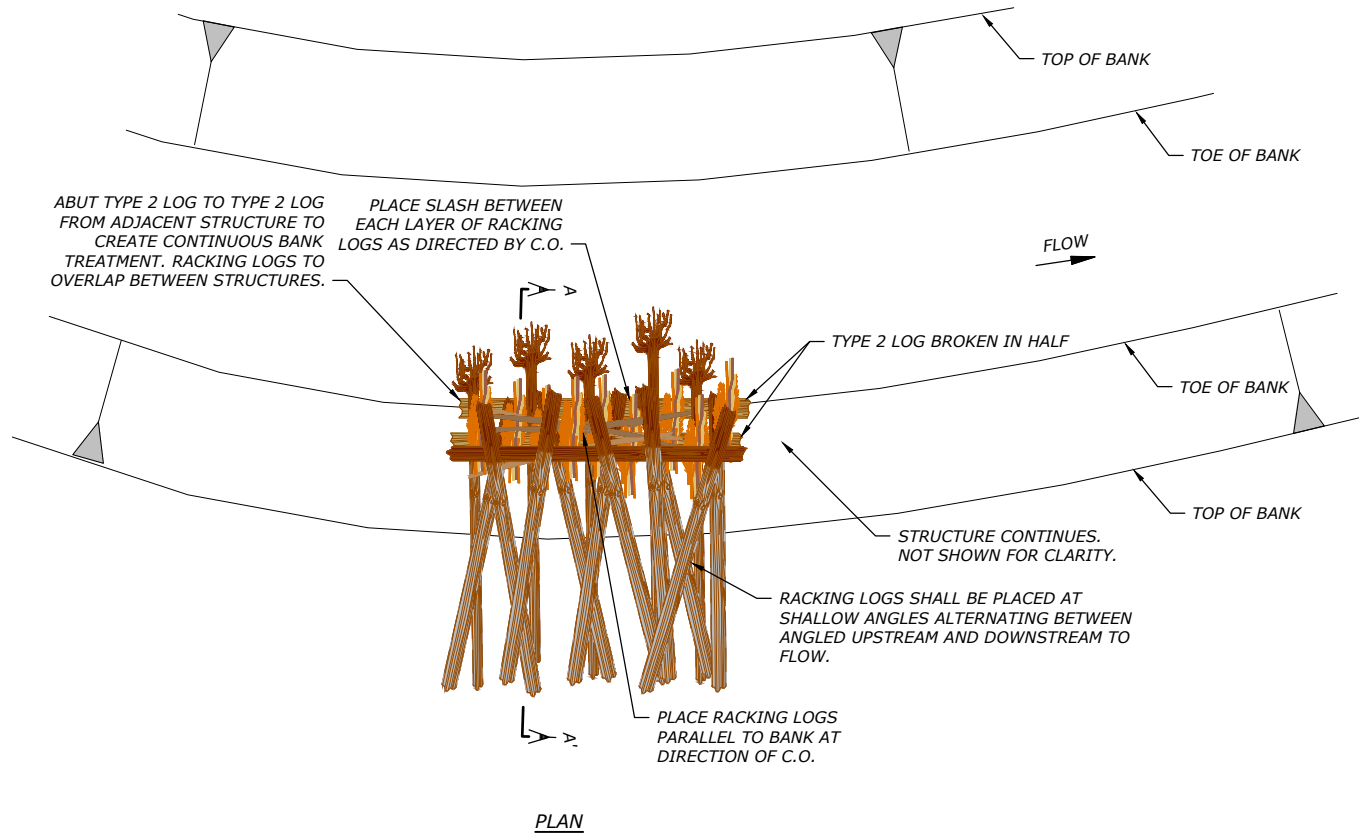

PLAN

**NOTES:**

1. ROUGHENED EDGE BANK TREATMENT SHALL BE CONSTRUCTED AT LOCATIONS AS SHOWN ON THE PLANS. THE EXACT LOCATION OF EACH OCCURRENCE OF BANK ROUGHNESS SHALL BE LOCATED BY THE CONTRACTOR AND APPROVED BY THE C.O. PRIOR TO CONSTRUCTING A PARTICULAR OCCURRENCE.
2. ALL EXPOSED ENDS OF KEY LOGS AND RACKING LOGS SHALL BE BROKEN. ALL EXPOSED CLEAN CUT ENDS OF LOGS WILL REQUIRE THE CONTRACTOR TO REPLACE WITH A BROKEN END AT NO ADDITIONAL EXPENSE.

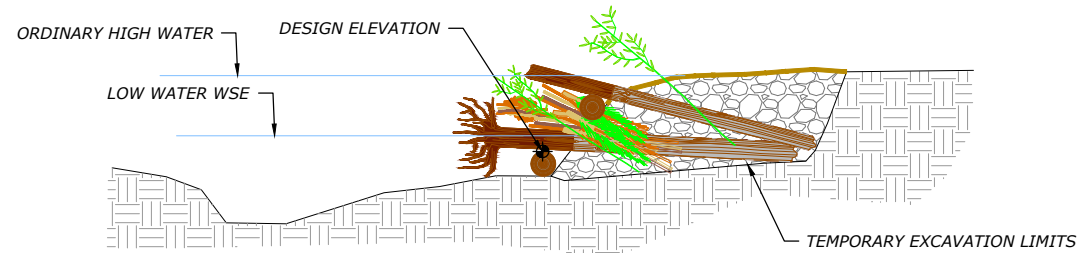

SECTION VIEW (A - A') SHORT ROUGHENED EDGE



METHOW RIVER FOGHORN REACH RESTORATION PROJECT PHASE 1

FINAL DESIGN DRAWINGS

FOR: YAKAMA NATION FISHERIES  
METHOW RIVER - FOGHORN REACH  
OKANOGAN COUNTY, WASHINGTON



DATE: APRIL 3, 2026  
DESIGNED: TDS, SJB  
APPROVED: JCY

DRAWING NAME  
DETAILS

ROUGHENED EDGE

DRAWING NO.  
D5  
SHEET 17 OF 19

**RIFFLE OVERVIEW NOTES:**

CONSTRUCTED RIFFLES ARE TO BE INSTALLED AT LOCATIONS SHOW IN THE GRADING PLANS. IF IN-SITU MATERIAL MEETS THE SPECIFICATION FOR RIFFLE MATERIAL PER THE GRADATION ON THIS SHEET THEN THE RIFFLE SHALL BE GRADED WITHOUT OVER-EXCAVATION AND PLACEMENT OF CONSTRUCTED RIFFLE MATERIAL. OTHERWISE, RIFFLE SHALL BE OVER-EXCAVATED AND CONSTRUCTED RIFFLE MATERIAL INSTALLED PER THE RIFFLE CONSTRUCTION STEPS OUTLINED ON THIS DRAWING.

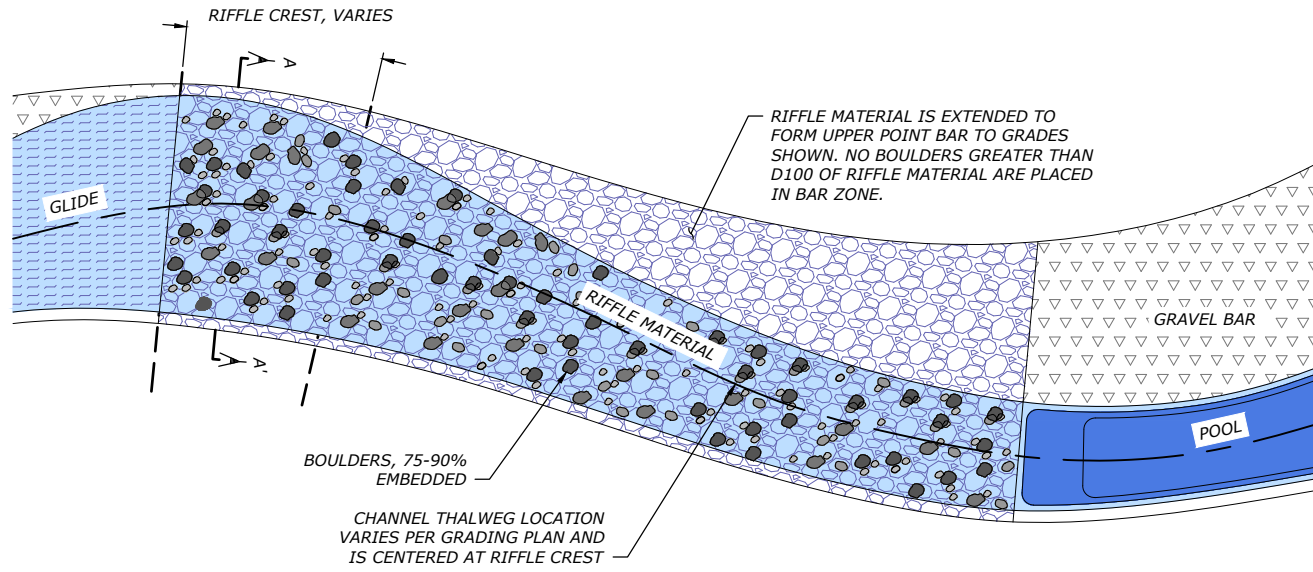

**PLAN**

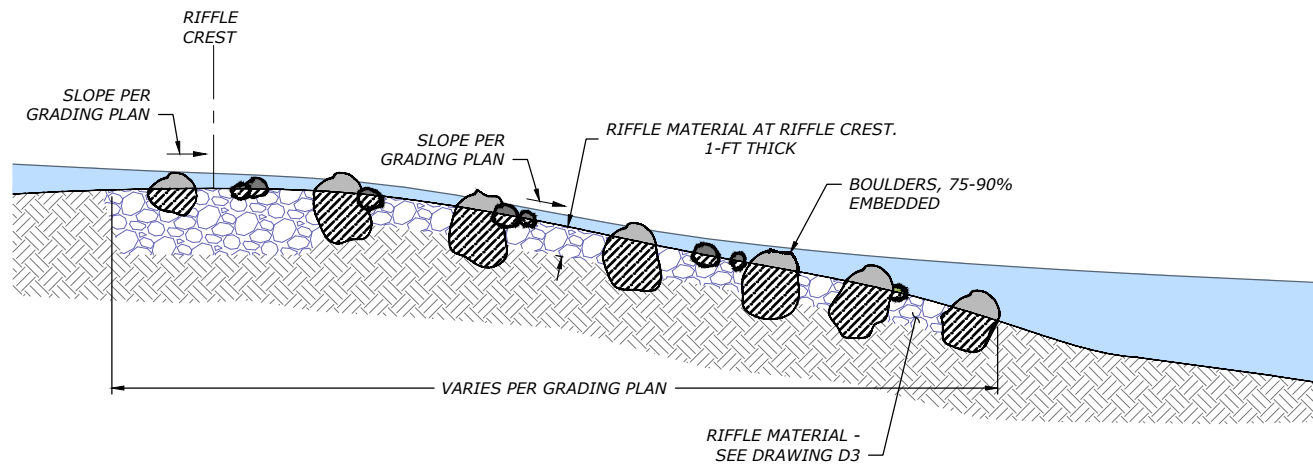

**PROFILE VIEW**

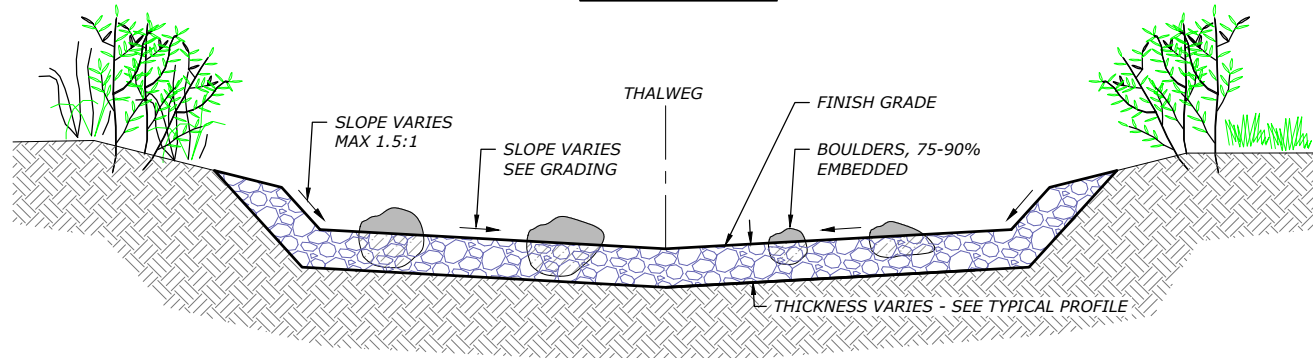

**SECTION A-A'**

**CONSTRUCTION SEQUENCING**

**STAGE 1 - ROUGH GRADE**

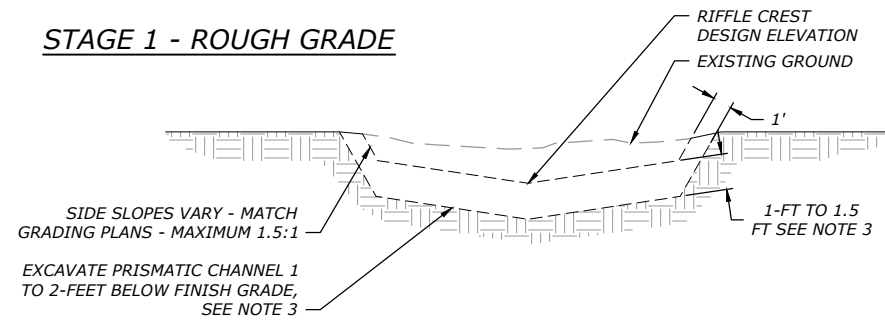

**STAGE 2 - FIRST LIFT\***

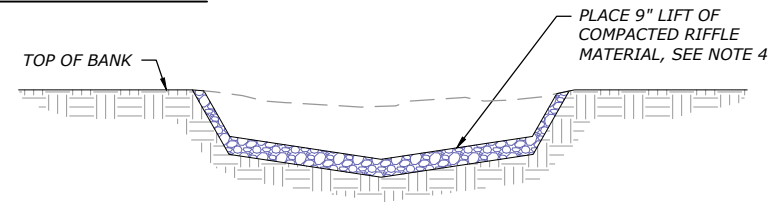

**STAGE 3 - SECOND LIFT\***

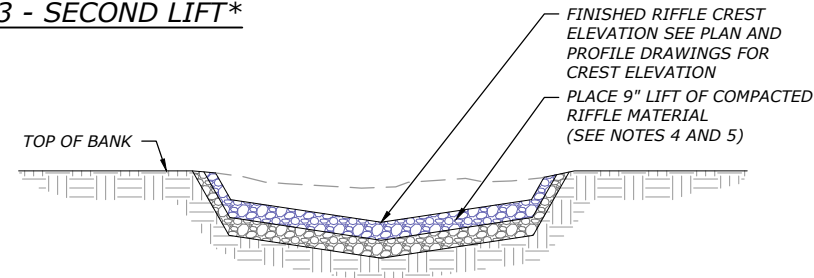

**STAGE 4 - BOULDER PLACMENT, BANK TREATMENT, AND TOP DRESSING**

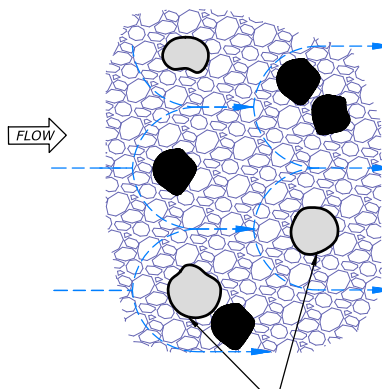
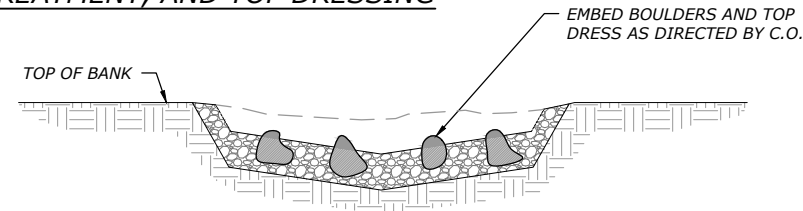

**BOULDER PLACEMENT**

**CONSTRUCTED RIFFLE NOTES:**

- STOCKPILE CHANNEL MATERIALS PER DESIGN SPECIFICATIONS. MATERIALS ARE TO BE STOCKPILED IN THE IMMEDIATE PROJECT AREA OR TRANSPORTED FROM THE SORTING AREA AS NEEDED.
- THREE PLACEMENTS ARE REQUIRED AS FOLLOWS:
  - CONSTRUCTED RIFFLE MATERIAL
  - LARGE AND SMALL BOULDERS (FOR EMBEDMENT)
  - ROUGHNESS ROCK (TOP DRESSING)
- TREAT EXISTING CHANNEL BED BY REMOVING ORGANICS AND CREATING A PRISMATIC WORKING SURFACE FOLLOWING CHANNEL THALWEG AND DESIGN CONTOURS ON GRADING DRAWINGS. ROUGH GRADE FROM FINISH GRADE TO SPECIFIED RIFFLE MATERIAL DEPTH IN CHANNEL BED IN ACCORDANCE WITH PLAN AND PROFILE DRAWINGS. ROUGH GRADE BANKS BY 1-FT TO SLOPES SHOWN ON GRADING PLANS AND NOT EXCEEDING 1.5:1.
- RIP EXISTING CHANNEL BED AT MINIMUM 4" DEEP TO CREATE A BETTER BONDING SURFACE BETWEEN THE TWO LAYERS.
- IMPORT WELL-MIXED RIFFLE MATERIAL AND/OR CREATE MATERIAL FROM NATIVE ALLUVIUM FROM PROJECT EXCAVATIONS MEETING THE SPECIFICATIONS FOR CONSTRUCTED RIFFLE MATERIAL. COMPACT RIFFLE MATERIAL IN 9-INCH LIFTS USING TRACKED 300 SERIES EXCAVATOR, OR SIMILAR EQUIPMENT AS APPROVED BY C.O. TRACK ON MATRIX MATERIAL SUFFICIENTLY TO COMPACT MATERIAL.
- REPEAT RIFFLE CONSTRUCTION BY PLACING ANOTHER 9-INCH LIFT WHERE REQUIRED TO MEET DESIGN FG AND CROSS SECTION SHAPE.
- BOULDERS OF VARIOUS SIZES ARE TO BE ADDED TO THE RIFFLE TO CREATE DIVERSE FLOW PATHS AND HABITAT.
- TOP DRESS WITH COARSE RIFFLE MATERIAL AS NEEDED AND DIRECTED BY C.O. TO ADD SOME INITIAL ROUGHNESS TO THE CHANNEL AND FORM A NATURAL APPEARANCE.
- FOR THOSE AREAS WHERE HABITAT STRUCTURES OR BANK TREATMENTS ARE TO BE PLACED ADJACENT TO THE CONSTRUCTED RIFFLE, THE RIFFLE WILL BE CONSTRUCTED BEFORE PLACEMENT OF HABITAT STRUCTURES OR BANK TREATMENTS.
- RIFFLES AND CHANNELS THAT ARE MARKED AS COMPLETE BY THE CONTRACTOR SHALL NOT BE DRIVEN ON BY MACHINERY TO PREVENT OVER COMPACTION OR MOVEMENT OF MATERIAL WITHOUT APPROVAL FROM C.O..

RIFFLE MATERIAL	
PERCENT PASSING	SIZE CLASS
100%	8.5 INCHES
84%	6.8 INCHES
50%	4.2 INCHES
30%	3.2 INCHES
16%	3.2 INCH
10%	0.2 INCH

**GRADATION NOTES:**

- PERCENT PASSING SIZE CLASS IS BASED ON THE NOMINAL DIAMETER OF ROCK.
- NOMINAL DIAMETER SHALL BE MEASURED AS THE INTERMEDIATE AXIS WHERE THE SMALL AND LARGE AXIS SHALL NOT BE MORE THAN 3 TIMES LESS THAN OR GREATER THAN THE NOMINAL DIAMETER.
- SIZE CLASS IS UNIQUE TO THESE DRAWINGS AND IS NOT THE UNIFIED SOIL CLASSIFICATION.
- ACCEPTABLE RIFFLE MATERIAL MAY BE CREATED FROM STOCKPILES OF VARIOUS SIZED SCREENED MATERIALS.



METHOW RIVER FOGHORN REACH RESTORATION PROJECT PHASE 1

FINAL DESIGN DRAWINGS

FOR: YAKAMA NATION FISHERIES  
METHOW RIVER - FOGHORN REACH  
OKANOGAN COUNTY, WASHINGTON



DATE: APRIL 3, 2026  
DESIGNED: TDS, SJB  
APPROVED: JCY

DRAWING NAME  
DETAILS

CONSTRUCTED RIFFLE

DRAWING NO.  
D6  
SHEET 18 OF 19

FILE: R:\PROJECTS\METHOW\_RIVER\_FOGHORN\_REACH\_RESTORATION\YALCAD\PRODUCTION\FOGHORN\_DETAILS.DWG SAVED BY: TIM STICKLES PLOT DATE: 4/2/2026 12:42 PM

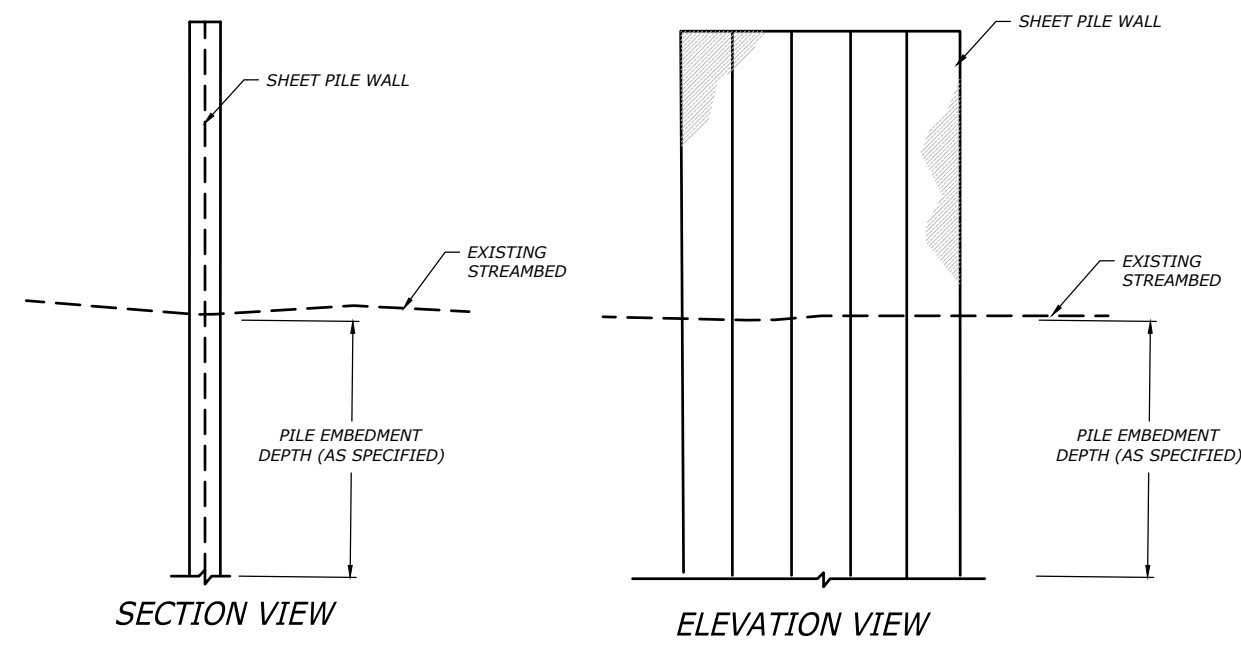

**7 SHEET PILE COFFERDAM**  
NTS

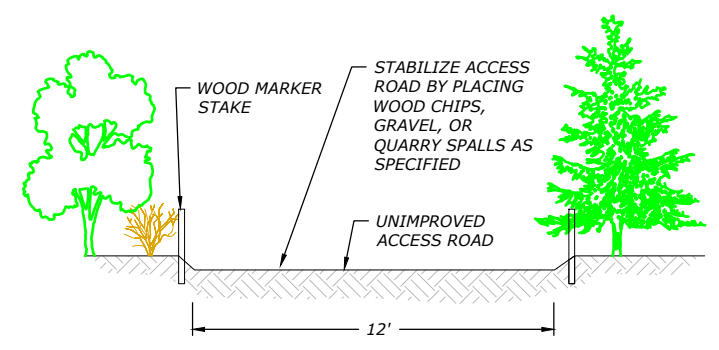

- NOTES:**
1. CLEARED ACCESS TO BE ROUTED TO MINIMIZE VEGETATION DISTURBANCE AND FOREST CLEARING.
  2. CONTRACTOR SHALL MARK CLEARING LIMITS. CLEARING LIMITS TO BE APPROVED BY ENGINEER PRIOR TO ANY CLEARING ACTIVITIES.
  3. ANY TREES GREATER THAN 18" Ø SHALL BE REMOVED W/ ROOTWADS INTACT AND STOCKPILED FOR USE IN LOGJAM CONSTRUCTION.
  4. TREES AND SHRUBS WITH 6"-18" Ø SHALL BE STOCKPILED FOR USE AS RACKING MATERIAL IN LOGJAM CONSTRUCTION.
  5. VEGETATION AND ORGANIC SOIL SHALL BE STRIPPED, TEMPORARILY STOCKPILED, AND REPLACED ON ROAD ALIGNMENT AFTER WORK IS COMPLETE AND ACCEPTED.
  6. ACCESS SHALL BE MAINTAINED BY MINOR GRADING AND PLACEMENT OF WOOD CHIPS, GRAVEL AND/OR QUARRY SPALLS. ALL GRAVEL OR QUARRY SPALLS (IF PLACED) SHALL BE UNDERLAIN WITH A GEOTEXTILE AND REMOVED.
  7. RESTORE ACCESS ROADS AND SEED IN ACCORDANCE WITH SEEDING SPECIFICATIONS.

**9 TEMPORARY ACCESS ROAD**  
NTS

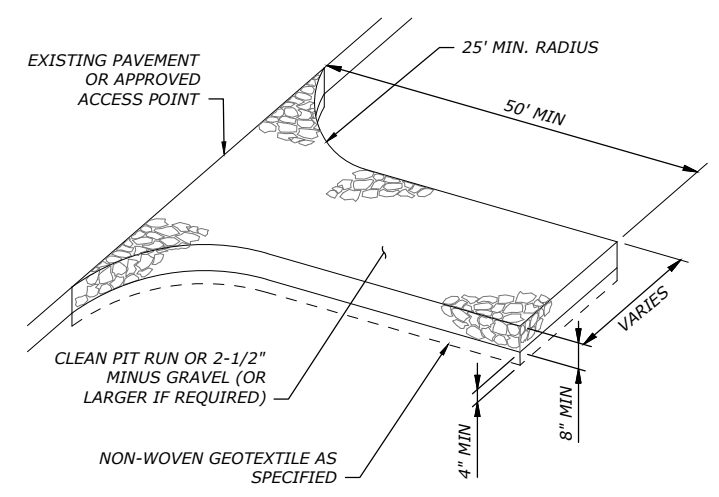

- NOTES:**
1. ADDITIONAL GRAVEL SHALL BE ADDED PERIODICALLY TO MAINTAIN PROPER FUNCTION OF THE PAD.
  2. REMOVE GRAVEL ENTRANCE AND REPLACE WITH BASE COURSE PRIOR TO COMPLETION OF THE PROJECT.

**8 CONSTRUCTION ENTRANCE**  
NTS

- BOLTED CONNECTION NOTES:**
1. ALL BARK SHALL BE REMOVED FROM BOTH LOGS AT THE CONNECTION POINT PRIOR TO INSTALLATION.

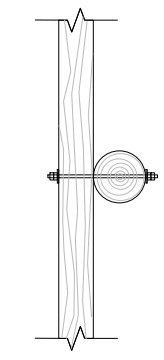

**10 BOLTED CONNECTION**  
NTS

- GENERAL EROSION AND SEDIMENT CONTROL AND WORK AREA ISOLATION NOTES:**
1. THE DETAILS SHOWN ON THIS SHEET ARE EXAMPLES OF ACCEPTABLE METHODS TO USE DURING CONSTRUCTION OF THIS PROJECT. THE CONTRACTOR IS RESPONSIBLE FOR DEVELOPING AND SUBMITTING A COFFERDAM, PUMPING, AND DEWATERING PLAN FOR REVIEW AND APPROVAL BY THE CONTRACTING AGENCY OR ENGINEER. THE PLAN SHALL INCLUDE SUFFICIENT DETAIL OF MEANS AND METHODS SATISFYINGLY MEETING THE PROJECT SPECIFICATIONS AND PERMIT REQUIREMENTS. IF APPROVED, OTHER METHODS MAY BE USED SUCH AS UTILIZING INFLATABLE BLADDERS, PLATES, OR BARRIERS OF VARIOUS MATERIALS. COFFERDAMS SHALL INCLUDE PLASTIC LINER OR FINE MESH SILT FENCE TO REDUCE TURBIDITY AND FINES FROM ENTERING THE FREE FLOWING PORTION OF LIVE WATER.
  2. COFFERDAMS SHALL BE CONSTRUCTED TO ACCOMMODATE ALL FLOW CONDITIONS AND WATER SURFACE ELEVATIONS EXPECTED DURING CONSTRUCTION PLUS A MINIMUM OF 1-FOOT OF FREEBOARD. THE CONTRACTOR SHALL BE SOLELY AND COMPLETELY RESPONSIBLE FOR COMPLIANCE WITH WATER QUALITY STANDARDS, SAFETY AND CONSTRUCTION STANDARDS, DAMAGE OR LOSS TO EQUIPMENT, MATERIALS, AND DAMAGES TO PRIVATE PROPERTY.
  3. THE CONTRACTING AGENCY IS RESPONSIBLE FOR MEASURING TURBIDITY HOWEVER THE CONTRACTOR SHALL ADHERE TO THE SPECIAL PROCEDURES REGARDING IN-STREAM WORK, TURBIDITY, AND DEWATERING (DRAWINGS G2). CONSERVATION MEASURES ARE SUMMARIZED ON DRAWINGS G3, G4, AND G5 AND SHALL BE STRICTLY ADHERED TO.
  4. THE CONTRACTOR SHALL NOTIFY THE OWNER AND CONTRACTING OFFICER AT LEAST 5 DAYS BEFORE EACH COFFERDAM INSTALLATION DATE SO THAT FISH SALVAGE ACTIVITIES CAN BE SCHEDULED. ANTICIPATED COFFERDAM LOCATIONS ARE SHOWN IN THE PLANS.
  5. FILL MATERIAL FOR BULK BAGS SHALL BE CLEAN, WASHED, AND ROUNDED MATERIAL MEETING STANDARD SPECIFICATIONS FOR DRAIN ROCK, STREAMBED AGGREGATES, STREAMBED SEDIMENTS, OR STREAMBED COBBLES. MATERIAL USED TO FILL BULK BAGS SHALL BE DISPOSED OF IN ACCORDANCE WITH THE PERMITS.
  6. DEWATERING PUMP DISCHARGE FROM WITHIN COFFERDAM WORK AREAS SHALL BE RELEASED ONTO FLOODPLAIN AREAS AWAY FROM CONSTRUCTION ACTIVITIES. DISCHARGE SHALL BE COMPLETELY INFILTRATED PRIOR TO REACHING SURFACE WATERS UNLESS APPROVED BY THE CONTRACTING OFFICER. ALL RETURN FLOWS MUST MEET PERMIT REQUIREMENTS FOR TURBIDITY.
  7. EXCAVATIONS ASSOCIATED WITH CHANNEL, FLOODPLAIN, AND WOOD HABITAT STRUCTURES SHALL BE DEWATERED IN ACCORDANCE WITH THE SPECIFICATIONS.
  8. ALL PUMP INTAKES SHALL BE SCREENED FOR FISH PROTECTION AS REQUIRED BY NOAA.
  9. ALL EARTHWORK ACTIVITIES AND WOOD HABITAT STRUCTURE CONSTRUCTION WITHIN THE ORDINARY HIGH WATER CHANNEL SHALL CONFORM TO THE WATER QUALITY STANDARDS ESTABLISHED BY REGULATORY AGENCY PERMITS FOR THIS PROJECT.



METHOW RIVER FOGHORN REACH  
RESTORATION PROJECT PHASE 1  
FINAL DESIGN DRAWINGS

FOR: YAKAMA NATION FISHERIES  
METHOW RIVER - FOGHORN REACH  
OKANOGAN COUNTY, WASHINGTON



DATE: APRIL 3, 2026  
DESIGNED: TDS, SJB  
APPROVED: JCY

DRAWING NAME  
DETAILS  
ACCESS & ISOLATION  
DETAILS

DRAWING NO.  
D7  
SHEET 19 OF 19

FILE: R:\PROJECTS\METHOW\_HUCS1\FOGHORN\_REACH\_RESTORATION\_YALCAD\PRODUCTION\FOGHORN\_DETAILS.DWG SAVED BY: TIM STICKLES PLOT DATE: 4/2/2026 12:42 PM

# Foghorn Reach Habitat Improvement Project Methow River Subbasin Okanogan County, Washington

Special Provisions to modify the Washington State Department of Transportation  
Standard Specifications for Road, Bridge and Municipal Construction (WSDOT  
Standard Specifications), 2024 Edition

Prepared by Rio Applied Science and Engineering (Rio ASE)  
for Yakama Nation Fisheries  
April 3, 2026



The person signing the specifications package shall have been in responsible charge of the overall design including developing or assembling the specifications. In cases where the designs described by the specifications meet the criteria for preparation by a registered engineer or architect, this person shall be registered with the applicable professional designation after their signature, such as P.E. for professional engineer or R.A. for registered architect. By this signature, this person is certifying the written specifications convey the design intent as portrayed on the drawings included therein. For specifications package containing designs from multiple disciplines, it is the signing individual's responsibility to ensure (using procedures defined by his/her organization) that the technical information prepared by other professions and disciplines and depicted in the document is compatible with the overall design intent and that the documents used to depict that information (e.g., drawings) include signatures with appropriate professional registration designations.

# Contents

<b>Other Submittals per WSDOT Standard Specifications</b> .....	4
<b>Division 1 - General Requirements</b> .....	5
<b>1-02 Bid Procedures and Conditions</b> .....	5
1-02.4 Examination of Plans, Specifications, and Site Work.....	5
1-02.4(2) Subsurface Information.....	5
<b>1-04 Scope of the Work</b> .....	5
1-04.4 Changes.....	5
<b>1-05.4 Conformity With and Deviations From Plans and Stakes</b> .....	6
<b>1-07 Legal Relations and Responsibilities to the Public</b> .....	6
1-07.1 Laws To Be Observed.....	6
1-07.2 State Taxes.....	6
1-07.5 Fish and Wildlife and Ecology Regulations.....	7
1-07.5(1) General.....	7
1-07.5(2) State Department of Fish and Wildlife.....	7
1-07.6 Permits and Licenses.....	7
1-07.15 Temporary Water Pollution Prevention.....	7
1-07.15(1) Spill Prevention, Control, and Countermeasures Plan.....	7
<b>1-08 Prosecution and Progress</b> .....	8
1-08.1 Subcontracting.....	8
1-08.2 Assignment.....	8
1-08.3 Progress Schedule.....	8
1-08.4 Prosecution of Work.....	8
1-08.5 Time for Completion.....	8
1-08.8 Extensions of Time.....	8
1-08.8(3) Wildfire.....	8
1-08.9 Liquidated Damages.....	8
1-08.10 Termination of Contract.....	8
<b>1-09 Measurement and Payment</b> .....	8
1-09.1 Measurement of Quantities.....	8
1-09.9 Payments.....	9
<b>1-10 Temporary Traffic Control</b> .....	9
1-10.5 Payment.....	9
<b>1-11 Safety Precautions</b> .....	9
<b>Division 2 - Earthwork</b> .....	11
<b>2-01 Clearing, Grubbing, and Roadside Cleanup</b> .....	11
2-01.1 Description.....	11
2-01.4 Measurement.....	11
2-01.5 Payment.....	11

<b>2-03</b>	<b>Roadway Excavation and Embankment</b>	12
2-03.1	Description	12
2-03.2	Materials	12
2-03.3	Construction Requirements	12
2-03.4	Measurement and Payment	13
<b>Division 8</b>	<b>Miscellaneous Construction</b>	14
<b>8-01</b>	<b>Erosion and Sediment Water Pollution Control</b>	14
8-01.1	Description	14
8-01.4	Measurement	14
8-01.5	Payment	14
<b>8-100</b>	<b>Water Management</b>	15
8-100.1	Description	15
8-100.2	Submittals	15
8-100.3	Materials	15
8-100.4	Construction Requirements	15
8-100.5	Measurement	16
8-100.6	Payment	16
<b>8-102</b>	<b>Wood Structures</b>	17
8-102.1	Description	17
8-102.2	Submittals	18
8-102.2(1)	Log Delivery Schedule	18
8-102.2(2)	Log Identification Tag Sample	18
8-102.3	Materials	18
8-102.4	Construction Requirements	20
8-102.5	Inspections	20
8-102.6	Measurement	20
8-102.7	Payment	21
<b>8-104</b>	<b>Temporary Construction Access, Staging, and Stockpile Areas</b>	22
8-104.1	Description	22
8-104.2	Submittals	22
8-104.3	Construction Requirements	22
8-104.4	Measurement and Payment	23

### List of Special Provision Submittals

- Erosion Sediment Control (ESC) plan
- Spill Prevention Control and Countermeasure (SPCC)
- Cofferdam Plan
- Pumping Plan
- Log Acquisition Plan
- Log Schedule
- Log Identification Tag Sample
- Access Plan
- Temporary Stream Crossing Plan

### Other Submittals per WSDOT Standard Specifications

- Construction Schedule (including milestones, start date, finish dates, etc.)
- Progress Schedule (submitted weekly throughout the duration of construction)
- Subcontractor List
- Pay Requests
- Emergency Telephone Number List
- Emergency Action Plan in Case of Workplace Injury
- Insurance Certificates
- Bond
- Safety Plan
- Record Drawings

### Submittal Notes:

- A. Time required to review submittals shall be (5) working days from the time the Contracting Officer receives a complete set of materials for a particular submittal.
- B. The Contracting Officer will indicate the approval or disapproval of each submittal and the reasons for disapproval. When each submittal has been approved, one copy will be returned to the Contractor.
- C. Obtain approvals on all submittals before beginning work on the items included in the submittal.

## Division 1 - General Requirements

### 1-02 Bid Procedures and Conditions

#### **1-02.4 Examination of Plans, Specifications, and Site Work**

Plans will be referred to as “Drawings” within these Special Provisions and these Special Provisions will be referred to as “Specifications” within the Drawings. Drawings and these Specifications will be made available by Yakama Nation Fisheries.

#### **1-02.4(2) Subsurface Information**

The Contracting Agency does not possess subsurface information for the project.

**END OF SECTION**

### 1-04 Scope of the Work

#### **1-04.4 Changes**

This section is supplemented with the following:

If Sponsor desires to order a change in the Work, it may request a written Change Order proposal from Contractor.

1. Due to the short and critical duration of this type of project, Contractor shall submit a Change Order proposal within 24 hours of the request from Sponsor, or within such other period as mutually agreed.
2. Contractor’s Change Order proposal shall be full compensation for implementing the proposed change in the Work, including any adjustment in the Contract Sum or Contract Time, and including compensation for all delays in connection with such change in the work and for any expense or inconvenience, disruption of schedule, or loss of efficiency or productivity occasioned by the change in Work.
3. Upon receipt of the Change Order proposal, or a request for equitable adjustment in the Contract Sum or Contract Time, Sponsor may accept or reject the proposal, request further documentation, or negotiate acceptable terms with the Contractor.
4. Pending agreement on the terms of the Change Order, Sponsor may direct Contractor to proceed immediately with the Change Order Work. Contractor shall not proceed with any change in the Work until it has obtained Sponsor’s approval. All Work done pursuant to any Sponsor-directed change in the Work shall be executed in accordance with the Contract Documents.
5. If Sponsor and Contractor reach agreement on the terms of any change in the Work, including any adjustment in the Contract Sum or Contract Time, such agreement shall be incorporated in a Change Order. The Change Order shall reflect full payment and final settlement of all claims for time and for direct, indirect and consequential costs, including costs of delays, inconvenience, disruption of schedule, or loss of efficiency or productivity, related to any Work either covered or affected by the Change Order, or related to the events giving rise to the request for equitable adjustment.
6. A request for an equitable adjustment in the Contract Sum shall be based on written notice delivered to the Sponsor within 24 hours of the occurrence of the event giving

rise to the request. For purposes of this part, “occurrence” means when Contractor knew, or in its diligent prosecution of the Work should have knowledge of the event giving rise to the request. If the Contractor believes it is entitled to an adjustment in the Contract Sum, Contractor shall immediately notify the Sponsor and begin to keep and maintain complete, accurate and specific daily records. Contractor shall give the Sponsor access to any such records and, if requested, shall promptly furnish copies of such records to Sponsor.

7. Contractor shall not be entitled to any adjustment in the Contract Sum for any occurrence of events or costs that occurred more than 24 hours before Contractor’s written notice to the Sponsor. The written notice shall set forth, at a minimum, a description of:
8. The event giving rise to the request for an equitable adjustment in the Contract Sum;
  - a. The nature of the impacts to Contractor and Subcontractors, if any; and,
  - b. To the extent possible, the amount of the adjustment in Contract Sum requested.
9. Failure to properly give such written notice shall, to the extent Sponsor’s interests are prejudiced, constitute a waiver of Contractor’s right to an equitable adjustment.
10. When the request for compensation relates to a delay or other change in Contract Time, Contractor shall demonstrate the impact on the critical path of the schedule attributable to the change of Work or event(s) giving rise to the request for equitable adjustment. Contractor shall be responsible for showing clearly on the Progress Schedule that the change or event:
  - a. Had specific impact on the critical path and, except in case of concurrent delay, was the sole cause of such impact; and
  - b. Could not have been avoided by re-sequencing of the Work or other reasonable alternatives.

**END OF SECTION**

**1-05.4 Conformity With and Deviations From Plans and Stakes**

Add the following:

- A. Contractor shall provide all surveying tasks necessary for construction. This includes, but is not limited to, locating grading limits, temporary access routes, temporary staging and stockpiling areas, and temporary contractor parking areas.

**END OF SECTION**

**1-07 Legal Relations and Responsibilities to the Public**

**1-07.1 Laws To Be Observed**

This section applies as written. Contractor shall review this section carefully and have a thorough understanding of all laws to be observed.

**1-07.2 State Taxes**

Delete 1-07.2(1) and 1-07.2(2) and replace with the following:

- A. This contract shall be exempt from Washington State Taxes.

**1-07.5 Fish and Wildlife and Ecology Regulations**

**1-07.5(1) General**

This section is supplemented with the following:

- A. The Sponsor has an HPA and permits or approvals from the Corps, Ecology and County which the contractor must abide by.
- B. This specification describes requirements originating from the Washington Department of Fish and Wildlife (WDFW), U.S. Fish & Wildlife Service (USFWS) and U.S. Army Corps of Engineers (ACOE) whose collective responsibility in this case is to make sure aquatic resources and fish communities are adequately protected during construction projects.
- C. The Contractor is advised that many of the requirements for protection of fish life, water quality, etc., are shown on Drawings, described in Division 8. Some other agency requirements are reflected in Specifications and/or Drawings related to site clearing, excavation limits, re-vegetation, etc.

**1-07.5(2) State Department of Fish and Wildlife**

This section is supplemented with the following:

- A. Prepare a Spill Prevention Countermeasures and Control Plan. Oil absorbent pads and personnel trained in spill prevention and control will be on site during all heavy equipment operations.
- B. Inspect heavy equipment at least on a daily basis for any leaks of petroleum products. Repair as needed.
- C. Heavy equipment needs to be pressure washed to be visibly free of all soil before shipping to the project site.

**1-07.6 Permits and Licenses**

This section is supplemented with the following:

- A. The Sponsor shall be responsible for obtaining all environmental permits required for construction, excluding business licenses and permits required for the Contractor's business. The Contractor shall be given a copy of the HPA and any other applicable permits. The Contractor shall comply with all permit requirements and always keep a copy of the permits on site.

**1-07.15 Temporary Water Pollution Prevention**

**1-07.15(1) Spill Prevention, Control, and Countermeasures Plan**

Add the following:

- A. This project shall adhere to specific Bonneville Power Administration's Habitat Improvement Programmatic (HIP) Conservations Measures summarized in the Drawings and shall be strictly adhered to.

- B. All work associated with Section 1-07.15(1) Spill Prevention, Control, and Countermeasures Plan and Section and including any amendments to work items shall be named “Environmental Controls.”

**END OF SECTION**

**1-08 Prosecution and Progress**

**1-08.1 Subcontracting**

This section does not apply. Refer to the requirements in the Construction Agreement.

**1-08.2 Assignment**

This section does not apply. Refer to the requirements in the Construction Agreement.

**1-08.3 Progress Schedule**

This section does not apply. Refer to the requirements in the Construction Agreement.

**1-08.4 Prosecution of Work**

This section does not apply. Refer to the requirements in the Construction Agreement.

**1-08.5 Time for Completion**

This section does not apply. Refer to the requirements in the Construction Agreement.

**1-08.8 Extensions of Time**

**1-08.8(3) Wildfire**

Add the following:

- A. Partial hoot owl, partial shutdowns, and general shutdowns may come into effect during the period of performance of the contract. For USFS Industrial Fire Precaution Levels, visit [https://www.fs.usda.gov/detail/okawen/alerts-notice/?cid=fsbdev3\\_053600](https://www.fs.usda.gov/detail/okawen/alerts-notice/?cid=fsbdev3_053600). No payment shall be made for standby time or delays resulting from natural disasters, including Industrial Fire Precaution Level work restrictions.

**1-08.9 Liquidated Damages**

This section does not apply. Refer to the requirements in the Construction Agreement.

**1-08.10 Termination of Contract**

This section does not apply. Refer to the requirements in the Construction Agreement.

**END OF SECTION**

**1-09 Measurement and Payment**

**1-09.1 Measurement of Quantities**

- A. Measurement for Mobilization and Demobilization will be by lump sum;
- B. Measurement for Environmental Controls will be by lump sum;
- C. Measurement for Temporary Construction Access will be by lump sum;
- D. Measurement for Cofferdams and Dewatering will be by lump sum;

E. Measurement for Construction Staking/Surveying will be by lump sum.

**1-09.9 Payments**

- A. Payment for Mobilization and Demobilization will be by lump sum and includes any/all labor, materials, and equipment required for temporary traffic control discussed in Section 1-10 and all appurtenances of required work not already itemized in the Bid Schedule.
- B. Payment for Environmental Controls will be by lump sum and includes all work associated with Section 1-07 Legal Relations and Responsibilities to the Public and Section 8-01 Erosion and Sediment Water Pollution Control (including preparing, implementing, and maintaining a Stormwater Pollution Prevention Plan (SWPPP) if required for the project and a Spill Prevention, Control, and Countermeasures Plan (required for the project).
- C. Payment for Temporary Construction Access will be by lump sum and includes any/all labor, materials, and equipment required for all work described in Section 2-01 Clearing, Grubbing, and Roadside Cleanup and Section 8-104 Temporary Construction Access, Staging, and Stockpile Areas.
- D. Payment for Cofferdams and Dewatering will be by lump sum and includes any/all labor, materials, and equipment required for all work described in Section 8-100 Water Management.
- E. Payment for Construction Staking/Surveying will be by lump sum and includes an/all labor, materials, and equipment required for all work described in Section 1-05.4 Conformity With and Deviations From Plans and Stakes.

**END OF SECTION**

**1-10 Temporary Traffic Control**

**1-10.5 Payment**

Measurement and payment for temporary traffic control for this project will be incidental to the Mobilization and Demobilization bid item regardless of the required procedures and devices used. Traffic control for the project shall conform to applicable traffic control standards.

**END OF SECTION**

**1-11 Safety Precautions**

This section is added:

- A. The Contractor shall be responsible for initiating, maintaining and supervising all safety precautions and programs in connection with the performance of the work.
- B. In carrying out its responsibilities according to the Contract Documents, Contractor shall protect the lives and health of employees performing the work and other persons who may be affected by the work; prevent damage to materials, supplies and equipment whether on site or stored off-site; and prevent damage to other property at the site or adjacent thereto. Contractor shall comply with chapter 296-800 WAC and all applicable laws, ordinances, rules, regulations and orders of any public body having jurisdiction for

the safety of persons or property or to protect them from damage, injury or loss; shall erect and maintain all necessary safeguards for such safety and protection; and shall notify owners of adjacent property and utilities when prosecution of the work may affect them.

- C. The Contractor shall maintain an accurate record of exposure data on all incidents relating to the work resulting in death, traumatic injury, occupational disease, or damage to property, materials, supplies or equipment. The Contractor shall immediately report any such incident to Sponsor and appropriate jurisdictions. The Sponsor shall, at all times, have a right of access to all records of exposure.
- D. All work shall be performed with due regard for the safety of the public. The Contractor shall perform the work so as to cause a minimum of interruption of vehicular traffic or inconvenience to pedestrians. All arrangements to care for such traffic shall be Contractor's responsibilities. All expenses involved in the maintenance of traffic by way of detours shall be borne by Contractor.
- E. In an emergency affecting the safety of life or the work or of adjoining property, Contractor is permitted to act, at its discretion, to prevent such threatened loss or injury, and Contractor shall so act if authorized or instructed.
- F. Nothing provided in this section shall be construed as imposing any duty upon the Sponsor with regard to, or as constituting any express or implied assumption of control or responsibility over, project site safety, or over any other safety conditions relation to employees or agents of the Contractor or any of its Subcontractors, or the public.

**END OF SECTION**

## Division 2 - Earthwork

### 2-01 Clearing, Grubbing, and Roadside Cleanup

#### **2-01.1 Description**

Add the following:

This section describes clearing activities necessary for construction. Grubbing is not expected for this project. Clearing is expected for areas required for temporary access routes, temporary staging and stockpiling areas, and temporary contractor parking areas and in accordance with Section 2-01 of the WSDOT Standard Specifications, and as amended:

- A. This project shall adhere to specific Conservations Measures summarized in the Drawings (Drawings G3 to G5) and shall be strictly adhered to.
- B. Areas for clearing shall be the minimum necessary and within the limits of disturbance (grading limits) shown on the Drawings and including temporary construction access routes, staging areas, stockpile areas, storage areas, and contractor parking areas.
- C. Clearing shall not occur outside of the designated grading limits.
- D. Disturbance of river banks and riparian vegetation shall be minimized and shall only include those areas marked by the Sponsor, Contracting Officer, or Engineer
- E. Removal of large trees, if necessary, shall be reused at the project site as woody material at the direction of the Contracting Officer.
- F. Shrubs removed during clearing and grubbing shall be left on site and placed outside of the limits of disturbance to be used as slash during installation of wood structures.
- G. Removal and salvage of trees and shrubs shall be considered incidental to clearing and grubbing.
- H. Vegetation and trees flagged for protection shall be completed by the Sponsor or Contracting Officer prior to clearing and grubbing activities. Vegetation protection during construction shall be incidental to clearing and grubbing.

#### **2-01.4 Measurement**

Measurement and compensation for all work described in Section 2-01 Clearing, Grubbing, and Roadside Cleanup shall be by lump sum (LS) as part of Temporary Construction Access.

#### **2-01.5 Payment**

Measurement and compensation for all work described in Section 2-01 Clearing, Grubbing, and Roadside Cleanup shall be by lump sum (LS) as part of Temporary Construction Access.

**END OF SECTION**

## 2-03 Roadway Excavation and Embankment

### 2-03.1 Description

Add the following:

This section describes the following work per the Drawings:

- A. Channel and Pool Excavation
- B. Excess material from project excavations
- C. Backfill for Wood Structures

### 2-03.2 Materials

Add the following:

- A. Native Alluvium
  1. Undisturbed ground excavated from within the limits of project excavations (channel excavations, excavations required for wood structure installation, etc.).
  2. Native Alluvium material shall meet WSDOT standard specifications for Streambed Aggregates, Streambed Sediment, or Streambed Cobbles generated from onsite excavations.
- B. Backfill for Wood Structures
  1. Shall be Native Alluvium unless otherwise specified in the Drawings. Native Alluvium material shall meet WSDOT standard specifications for Streambed Aggregates, Streambed Sediment, or Streambed Cobbles generated from onsite excavations.
  2. If Native Alluvium is not specified for backfill, the material shall be developed onsite by the Contractor by screening and mixing stockpiles of Native Alluvium with imported alluvium material with the gradation specified in the Drawings.
  3. Imported alluvium material shall be furnished by the Contractor from an offsite borrow source identified by the Contractor and approved by the Contracting Officer. The material shall be sub-angular and approved by the Contracting Officer prior to transporting it to the project site.
  4. Consists of a well-graded mixture of sand, gravel, cobble, and boulders meeting the gradation specified in the Drawings.
  5. Percent passing in the gradation size class is based on the nominal diameter of rock. Nominal diameter shall be measured as the intermediate axis where the small and large axis shall not be more than 3 times less than or greater than the nominal diameter. Size class is unique to these Drawings and is not based on the Unified Soil Classification.

### 2-03.3 Construction Requirements

Add the following:

- A. Excavation
  1. Perform channel excavations to the lines and grades shown in the Drawings, or by field clarification by the Contracting Officer.

2. Channel excavation includes excavation for channels and pools (including pools for wood structures if not already included as part of excavation of channels).
  3. Finish grades shall be within  $\pm 0.5$  feet horizontal and  $\pm 0.10$  feet vertical of the locations and elevations shown on the Drawings unless otherwise approved by the Contracting Officer or Engineer.
  4. Finish grades shall be flush with adjacent surfaces unless otherwise indicated.
  5. Finish grades shall be inspected and approved by the Contracting Officer or Engineer prior to rewatering of a current work segment or removing cofferdams. The Contracting Officer or Engineer will flag areas that should be adjusted and reviewed with the Contractor. The Contractor is responsible for making all adjustments prior to rewatering or removing cofferdams.
- B. Excess material from project excavations
1. Native Alluvium material generated through all project excavations and not used to create Constructed Riffle Material or used in areas of general fill shall be spoiled onsite at locations determined by the Contracting Officer.
- C. Backfill for Wood Structures
1. Shall be in accordance with the requirements specified in the Drawings.

#### **2-03.4 Measurement and Payment**

- A. Channel Excavation (cut)
1. Measurement and payment shall be by the cubic yard measured in its original position not factored for expansion or compaction.
  2. For progress payments, the Contracting Officer (using visual estimate or other agreed upon means) shall estimate the percent complete based on the completed portion of the total proposed excavation area multiplied by the estimated excavation quantity reported in the Engineers Quantity Estimate in the Drawings. Includes full compensation for all materials, labor, equipment, temporary stockpiling, and all appurtenances not itemized in the Bid Schedule necessary or required to perform the work.
- B. Excavation, over-excavation, and backfill required to install wood structures shall be incidental to the installation of wood structures.
- C. Pool excavation shall be measured and paid for under Channel Excavation (cut).
- D. Placement of excess channel excavation material to be placed onsite at the direction of the Contracting Officer is considered incidental to Channel Excavation (cut).
- E. For progress payments, the Contracting Officer (using visual estimate or other agreed upon means) shall estimate the percent complete based on the completed portion of the total proposed excavation area. Includes full compensation for all materials, labor, equipment, temporary stockpiling, haul, and all appurtenances not itemized in the Bid Schedule.

**END OF SECTION**

## Division 8 – Miscellaneous Construction

### 8-01 Erosion and Sediment Water Pollution Control

#### **8-01.1 Description**

Add the following:

This work shall provide for preparation and implementation of an Erosion Control and Water Pollution Control plan including removal of associated items in accordance with Section 8-01 of the Standard Specifications, and as amended by these special provisions:

- A. If required for the project (based on disturbance area), the Contractor shall be responsible for preparing, implementing, and maintaining a Stormwater Pollution Prevention Plan (SWPPP).
- B. This project shall adhere to specific Conservation Measures summarized in the Drawings (Drawings G3 to G5).
- C. This item includes silt/sediment fence installed around the perimeter of all staging areas.
- D. This item includes installation of a construction entrance at locations identified in the Drawings.
- E. This item includes proper environmental controls with emphasis on dust control at the project site. Performing dust abatement shall be a critical component of project implementation. The Contractor shall properly monitor and mitigate dust with all construction activities beginning with mobilization.

#### **8-01.4 Measurement**

- A. All work associated with 8-01 Erosion and Sediment Water Pollution Control shall be measured and paid as part of Environmental Controls by lump sum.

#### **8-01.5 Payment**

- A. All work associated with 8-01 Erosion and Sediment Water Pollution Control shall be measured and paid as part of Environmental Controls by lump sum.

**END OF SECTION**

## 8-100 Water Management

This section is added.

### 8-100.1 Description

The work consists of furnishing, installing, monitoring, maintaining, and removing cofferdams as needed to effectively construct proposed features, and coordinating with the Contracting Officer for fish salvage activities. The work also consists of furnishing, monitoring, operating, maintaining, removing pumps, and control of discharge water. Fish salvage is not the responsibility of the Contractor. Fish salvage will be coordinated and led by the Contracting Officer and completed by project partners if deemed necessary.

### 8-100.2 Submittals

The Contractor is responsible for developing and submitting a Cofferdam Plan for review and approval by the Engineer to include sufficient detail of means and methods satisfyingly meeting the Drawings, Specifications, permit requirements, and Conservation Measures. See Drawings for examples of acceptable cofferdam methods and associated notes.

The Contractor is responsible for developing and submitting a Pumping Plan for review and approval by the Engineer to include sufficient detail of means and methods satisfyingly meeting the Drawings, Specifications, permit requirements, and Conservation Measures. The Pumping Plan shall include the expected equipment (number of pumps, pump types, pump sizes, length of discharge hose, etc.). Electric pumps with generators and quiet packs are preferred. The Pumping Plan shall also include locations for discharge water and types of environmental protection measures. If infiltration becomes an ineffective means to control turbidity, additional and alternative methods shall still comply with all associated Permit Provisions (such as pumping to stilling basins) and shall be at the Contractor's expense.

### 8-100.3 Materials

The Contractor shall provide all required materials for the project.

### 8-100.4 Construction Requirements

- A. The Sponsor is responsible for measuring turbidity however the Contractor shall adhere to the special procedures regarding in-stream work, turbidity, and dewatering as defined within Bonneville Power Administration's Habitat Improvements Programmatic Conservation Measures and Department of Ecology's restrictions whichever is more stringent. Additionally, this project shall adhere to specific Conservations Measures summarized in the Drawings (Drawings G3 to G5).
- B. The Contractor shall notify the Contracting Officer at least 5 days before each cofferdam installation date so that fish salvage activities can be scheduled.
- C. Fill material for sandbags or "super sacks", if used, shall be clean, washed, and rounded material meeting WSDOT standard specifications for Drain Rock, Streambed Aggregates, Streambed Sediments, or Streambed Cobbles. Material used to fill bulk bags may be disposed of onsite if the permits allow. The Contractor shall coordinate with the Contracting Officer regarding disposal. Otherwise, the material shall be removed from the project site and properly disposed of at the end of construction. Disposal of the

material within newly excavated channels including inlets and outlets shall not be permitted.

- B. Dewatering within excavated channels shall be performed such that the Contractor can sufficiently construct all features and the Contracting Officer can easily inspect and measure the finished elevation of the channel bed.
- C. If the Contractor attempts to construct a portion of the project without fully dewatering the site and is unable to construct the item as shown on the Drawings to the satisfaction of the Contracting Officer, the Contractor shall receive no additional compensation for removing and replacing unacceptable work including dewatering associated with removing and replacing work.
- D. Dewatering pump discharge from within work areas shall be released onto floodplain areas at locations identified in the Drawings or at locations approved by the Contracting Officer (per an approved Pumping Plan) away from wetlands and construction activities. Discharge shall be completely infiltrated prior to reaching wetlands or surface waters unless approved by the Contracting Officer. All return flows must meet permit requirements for turbidity.
- E. All pump intakes shall be screened for fish protection as required by NOAA.
- F. All earthwork and wood structure construction within the ordinary high-water limits shall conform to the water quality standards established by regulatory agency permits for this project.

**8-100.5 Measurement**

- A. All work associated with 8-100 Water Management shall be measured and paid as part of Cofferdams and Dewatering by lump sum.

**8-100.6 Payment**

- A. All work associated with 8-100 Water Management shall be measured and paid as part of Cofferdams and Dewatering by lump sum.

**END OF SECTION**

## 8-102 Wood Structures

This section is added.

### 8-102.1 Description

The work consists of procuring and delivering woody material and boulders to the site, storing material, hauling and handling, and construction of wood structures (including excavation, adjacent pool excavation, placement of wood and boulders, and backfilling of structures) as detailed in the Drawings. **The Sponsor has obtained all Type 1 and 2 logs required for the project however the Contractor will be required to transport them to the project site.**

- A. Woody material shall be procured at a source identified by the Contractor.
- B. Woody material shall be delivered to the Project Site meeting all applicable highway traffic laws for maximum weight and length requirements for the most restrictive segment of public road along the proposed haul route.
- C. The Contractor is responsible for obtaining all necessary highway hauling permits. Woody material shall be inspected at the time of delivery and shall not be offloaded until accepted by the Contracting Officer. All Type 1, 2, and 3 logs shall be marked with a ring of paint near the dbh measurement. Each log type shall have a distinct paint color for ease of identification and measurement of quantity. Racking and slash material shall be stockpiled in separate piles.
- D. The Contractor shall provide the Contracting Officer a materials manifest that itemizes the size and species of all material delivered on a per truckload basis. Each manifest of accepted woody material shall become the record to determine the balance of acceptable material delivered and the basis for measurement and payment.
- E. Wood material shall be offloaded at designated staging areas and stacked in neat piles, separating material types as directed by the Contracting Officer. Offloading and stacking of material shall be done with care to avoid damage to branch structure, rootwad structure, and log integrity. Any woody material determined to be damaged during offloading and handling in the stacking process will be rejected and removed from the Project Site at the Contractor's expense.
- F. Woody material determined to be damaged during offloading and handling to individual wood structure sites will be rejected and removed from the Project Site at the Contractor's expense. The Contracting Officer may test for disease, decay or insect infestation through the use of visual or manual inspection. Disposal of rejected woody material is the responsibility of the Contractor but must be done in a legal fashion and at the Contractor's expense. No dumping or abandoning is allowed. Under special circumstances and with approval by the Contracting Officer, rejected woody material may be left onsite.
- G. Woody material determined to be damaged during installation will be rejected and removed from the Project Site at the Contractor's expense. Rootwads shall have intact root balls measuring a minimum diameter as shown on the Drawings (Sheet G6) and shall be inspected during and immediately after construction of each structure.

## **8-102.2 Submittals**

### **8-102.2(1) Log Delivery Schedule**

Submit a detailed list of individual logs delivered as specified in the Drawings and these specifications. The list shall include species type, log diameter (at breast height), log diameter (at tip), rootwad diameter (as measured to root tips capable of supporting the log), and log lengths (log length includes rootwad, as applicable).

### **8-102.2(2) Log Identification Tag Sample**

Submit a written description of the proposed log identification tag discussed in the Construction Requirements section including unique number identifier sequence.

## **8-102.3 Materials**

The Contractor shall provide all required materials for the project.

- A. **The Sponsor has obtained all Type 1 and 2 logs required for the project however the Contractor will be required to transport them to the project site.**
- B. Tree material shall be free of disease, insect infestation and rot. Fungal staining is acceptable unless the fungal growth is evidenced as rot.
- C. Tree material shall be unseasoned (green) material. Tree material that has been previously burned may be allowed under certain circumstances and must be approved for use prior to delivery by the Contracting Officer.
- D. Tree material shall generally be sound in nature and free from excessive checks and shakes. Excessive checking shall mean continuous longitudinal checks exceeding 20 percent of the log length with a depth exceeding 20 percent of the diameter of the log. Excessive shakes shall mean continuous circumferential cracking that exceeds 50% of the circumference of the log.
- E. Preferred genus and species are:
  1. Douglas Fir
  2. Ponderosa Pine
  3. Larch
  4. Western Red Cedar
- F. The Contractor shall submit locations of wood acquisition sites for approval by the Contracting Officer prior to any harvesting activities begin. Depending on availability of material, alternate species may be submitted for consideration, and must be approved by the Contracting Officer.
- G. Logs may be with or without bark and may have branches/stubs remaining (preferred). Diameter of each log shall be as indicated in the section below and shall be the specified minimum diameter at breast height (dbh) not including the bark. For logs without rootwads the diameter of the log will be determined by measuring one foot in from the largest of the cut ends. Length of each log shall be as indicated in the section below.
- H. Rootwads (when required) shall be free of loose accumulations of dirt and rocks that may contribute to the turbidity of the river when immersed. Rootwads shall have intact root balls measuring a minimum of 4 times the log DBH.
- I. Racking material shall meet the same material specifications as tree materials including genus and species identified above.

- J. Live Stakes shall be installed within wood habitat structures as specified in the Drawings. Requirements for Live Stakes are discussed in Section 8-105.

#### Type 1 Logs

- A. Refer to the Drawings (Sheet G6) for the number of Type 1 Logs required for this contract.
- B. Type 1 Logs shall have a dbh of 18 to 24 inches, and a length of 35 to 40 feet.
- C. Type 1 logs shall have an intact rootwad with a minimum diameter of 5 feet.

#### Type 2 Logs

- A. Refer to the Drawings (Sheet G6) for the number of Type 2 Logs required for this contract.
- B. Type 2 Logs shall have a dbh of 18 to 24 inches, and a length of 30 to 35 feet.
- C. Type 2 logs shall have an intact rootwad with a minimum diameter of 4.5 feet.

#### Type 3 Logs

- A. Refer to the Drawings (Sheet G6) for the number of Type 3 Logs required for this contract.
- B. Type 3 Logs shall have a dbh of 18 to 24 inches, and a length of 25 to 30 feet.
- C. Type 3 logs shall not have an intact rootwad.

#### Racking Wood Material

- A. Refer to the Drawings (Sheet G6) for the number of Racking – 1 pieces required for this contract.
- B. Racking pieces shall have a dbh of 6 to 14 inches, and a length of 15 to 25 feet.
- C. Racking pieces shall have an intact rootwad measuring a minimum of 2.5 feet in diameter.
- D. Racking material consists of small diameter logs, tree tops or branches with branches intact.
- E. Racking shall come from fir, pine or spruce trees. A minimum of 50% of the racking shall come from Douglas fir, grand fir, or spruce trees.

#### Slash Material

- A. Refer to Drawings (Sheet G6) for volume of Slash – 1 material required for this contract.
- B. Slash material shall be from the harvested trees and logs delivered to the project site or shall consist of dense vegetative debris including, but not limited to small trees, broken tops, limbs, branches, brush, saplings or poles.
- C. Slash shall be any native conifer or hardwood species. Length of individual pieces of slash may vary between 5-15 feet. Diameter of main slash pieces may vary from 1 to 4-inches diameter, with typical piece thickness between 2 and 4-inches diameter.
- D. Slash shall be free of soil and rocks to the greatest extent practicable.

#### Backfill Material for all Wood Habitat Structures

- A. Shall be native alluvium material meeting the WSDOT standard specifications for Streambed Aggregates, Streambed Sediment, or Streambed Cobbles generated from onsite excavations.

#### **8-102.4 Construction Requirements**

- A. See the Drawings for specific construction requirements regarding construction of wood structures.
- B. Each individual Log larger than ten feet in length and 12" inches in diameter shall be tagged with a unique numerical identifier that will withstand typical river conditions for at least three years. Tags shall be round aluminum tags measuring 1-1/4" diameter x 0.050" thick with a 3/16" diameter hole. Tags shall be fastened to each individual logs meeting the above criteria using a 2.5" nail or otherwise approved fastener. Tags shall be placed at inconspicuous locations that are not visible such as the underside of logs or covered or buried portions of logs.
- C. All logs shall be placed as shown on the Drawings or as directed by the Contracting Officer. Each type of structure has detailed methods of construction and layout of specific logs in specific sequence. The Contractor shall pay careful attention to the type, size and orientation of all logs as shown on the Drawings.
- D. The Contractor shall excavate scour pools in the channel bed near habitat structures as shown in the Drawings or as directed by the Contracting Officer.
- E. Where called for in the Drawings the Contractor shall place boulders as designated in the Drawings or as directed by the Contracting Officer or Engineer.
- F. Place structure backfill material at the locations shown on the Drawings and to the elevations shown on the Drawings unless otherwise directed by the Contracting Officer. Structure backfill shall be carefully placed over logs as indicated on the Drawings. Material shall be placed in lifts with a maximum 12-inch lift height, and with each lift compacted to at least 85% relative compaction prior to placing subsequent lift. No testing of compacted density will be performed, acceptance will be by the Contracting Officer observing fill placement and compaction effort.
- G. Pile Logs shall be vibrated or excavated in.

#### **8-102.5 Inspections**

Contracting Officer shall perform inspections upon delivery and again upon installation.

#### **8-102.6 Measurement**

Use the following unit price option as designated on the Bid Schedule for acquiring woody materials. Includes all labor, materials, and equipment for loading, unloading, and hauling woody materials and boulders from approved source locations to staging areas within the project area as directed by the Contracting Officer:

- A. All work associated with acquiring any/all woody materials required for the project shall be measured and paid as part of Wood Material Acquisition and Delivery by lump sum. Quantities of Type 1, Type 2, Type 3, Racking, and Slash material required for the project shown on Drawing G6. Shall include all appurtenances not already itemized in the Bid Schedule and include all work required for obtaining necessary permits, shipping, loading, transporting, unloading, etc.

Use the following unit price option as designated on the Bid Schedule. Includes all labor, materials and equipment for loading and unloaded, hauling materials from project staging areas to installation sites and installation of log structures including placement of logs, tagging logs, bolted connections, boulders, excavation, and backfill:

- A. Habitat Structure - 1: Measurement shall be by per each structure (EA)
- B. Habitat Structure - 2: Measurement shall be by per each structure (EA)
- C. Habitat Structure - 3: Measurement shall be by per each structure (EA)
- D. Habitat Structure - 4: Measurement shall be by per each structure (EA)
- E. Roughened Edge Bank Treatment: Measurement shall be by length of treatment (LF)

**8-102.7 Payment**

Payment for acquisition of woody material shall be as follows:

- A. Wood Material Acquisition and Delivery: Payment shall be by lump sum (LS). Quantities of Type 1, Type 2, Type 3, Racking, and Slash material required for the project shown on Drawing G6. Shall include all appurtenances not already itemized in the Bid Schedule and include all work required for obtaining necessary permits, shipping, loading, transporting, unloading, etc.

Payment for log structure installation shall be as follows:

- A. Habitat Structure - 1: Payment shall be by per each structure (EA)
- B. Habitat Structure - 2: Payment shall be by per each structure (EA)
- C. Habitat Structure - 3: Payment shall be by per each structure (EA)
- D. Habitat Structure - 4: Payment shall be by per each structure (EA)
- E. Roughened Edge Bank Treatment: Payment shall be by length of treatment (LF)

**END OF SECTION**

## 8-104 Temporary Construction Access, Staging, and Stockpile Areas

This section is added.

### 8-104.1 Description

- A. The work consists of furnishing, monitoring, and maintaining temporary construction access routes, stabilized access routes, staging areas, stockpile areas, temporary construction entrance, temporary stream crossing, and other contractor use areas.

### 8-104.2 Submittals

- A. The Contractor is responsible for developing and submitting an Access Plan for review and approval by the Engineer to include sufficient detail of means and methods satisfyingly meeting the Drawings and Specifications for the installation of Temporary Stabilized Construction Access Routes. The plan shall include expected locations, equipment, and materials.

### 8-104.3 Construction Requirements

#### 8-104.3(1) Temporary Construction Access Route

- A. All Temporary Construction Access Routes are depicted in the Drawings. Contractor may not deviate from these locations without prior approval from the Contracting Officer.
- B. Contractor shall establish a 12' wide access routes with sufficient load-bearing capacity to provide unimpeded traffic for construction purposes.
- C. Wetlands, saturated soils, and mature vegetation shall be avoided. If necessary, temporary access routes shall be modified at the direction of the Contracting Officer to avoid these areas. If conflicts cannot be avoided, then installation of Temporary Stabilized Construction Access Routes may be required at the direction of the Contracting Officer.
- D. Maintain all Temporary Construction Access Routes in a sound and serviceable condition until project completion and acceptance of work.
- E. Temporary Construction Access Routes shall be de-compacted in accordance with Section 8-105 at project completion and returned to pre-existing conditions.

#### 8-104.3(2) Temporary Stabilized Construction Access Route

- A. Temporary Stabilized Access Routes shall be installed where temporary routes used for construction traverse wetlands, saturated soils, or sensitive areas. At these locations, wetland sod/vegetation/organic layer shall be stripped and stockpiled adjacent to the access route. Contractor shall then install a minimum of 12" of wood chips (aka. hog fuel) or mulch. Otherwise, gravel underlain with non-woven geotextile road fabric may be used.
- B. All materials shall be removed and properly disposed of at project completion, decompacted in accordance Section 8-105, and wetland sod/vegetation replaced/returned to pre-existing conditions.
- C. Maintain all Temporary Stabilized Access Routes in a sound and serviceable condition until project completion and acceptance of work.

#### 8-104.3(3) Temporary Staging and Material Stockpile Area

- A. The Contractor shall park all equipment, vehicles, materials, fuel, portable sanitation facilities, etc. on the sod in the designated Temporary Construction Staging and Material Stockpile Area designated in the Drawings. Do not strip the surface in accordance with the Conservation Measures in the Drawings (Drawings G3 to G5).
- B. All equipment and vehicles shall be stored in the Temporary Construction Staging Area each night.

**8-104.3(4) Temporary Construction Entrance**

- A. Contractor shall install Temporary Construction Entrances at location designated in the Drawings and in accordance with the detail on Drawing D7.

**8-104.4 Measurement and Payment**

Use the following unit price option as designated on the Bid Schedule. Includes all labor, materials and equipment for loading, hauling and unloading of materials to the project site and installation, including excavation and backfill, and removal and disposal of materials:

- A. All work described in 8-104 Temporary Construction Access, Staging, and Stockpile Areas shall be measured and paid for by lump sum (LS) as part of the Temporary Construction Access bid item.

**END OF SECTION**